

PART A: PRODUCT DESCRIPTION,
INSTALLATION AND OPERATION
AWIFLEX
AWITE
BIOENERGIE



Original Instruction Manual
(Version: 18.5)

Contact and Imprint

Please find the latest information online at www.awite.com . For any questions, comments or suggestions, please send an email to info@awite.com .

Awite Bioenergie GmbH
Grünseiboldsdorfer Weg 5
85416 Langenbach/Niederhummel, Germany

Phone: +49 8761 / 72 162 - 0

Fax: +49 8761 / 72 162 - 11

Email: info@awite.com

<http://www.awite.com>

© 2023 Awite Bioenergie GmbH
Errors and changes reserved

Table of Contents

1	Preface.....	6
2	Identification.....	7
3	Safety Instructions Part A.....	8
4	Product description.....	12
4.1	Intended Usage.....	12
4.2	Device Category According to ATEX Classification.....	13
4.2.1	Device category not intended for installation in an Ex-zone.....	13
4.2.2	Device category intended for installation in an Ex-zone 2.....	13
4.2.2.1	Safety device for monitoring the interior space.....	14
4.3	Description of the Gas Analysis System and Dimensions.....	15
4.4	Ambient Conditions and Limits for Operation and Storage.....	18
4.4.1	Installation location.....	18
4.4.2	Installation height.....	18
4.4.3	Ambient Temperature.....	18
4.4.4	Ambient humidity.....	18
4.4.5	Mains voltage fluctuations.....	18
4.4.6	Overvoltage category.....	19
4.4.7	Wetness and degree of pollution in the environment.....	19
4.4.8	Measuring gas pressure.....	19
4.4.9	Measuring gas, fresh air and exhaust air requirements.....	19
4.5	Hazards from gas.....	20
4.5.1	Zone division.....	20
4.5.2	Flame or explosion propagation over gas bearing lines.....	20
4.5.3	Leakage in the Measuring Gas Supply Line.....	21
4.5.4	Gas volume.....	21
4.5.5	Leaks in the Gas Analysis System.....	21
4.5.6	Release of Potentially Toxic and Harmful Gases.....	21
5	Preparing the Gas Analysis System for Use.....	23
5.1	Transport and Storage.....	23
5.2	Installation.....	23
5.2.1	Main Switch Mains Disconnection Facility.....	24
5.2.2	Terminal boxes for electrical connections.....	24
5.2.2.1	Terminal Boxes AwifLEX.....	25
5.2.2.2	Connection Cable 100-240 V for Power Supply.....	25

Table of Contents

5.2.2.3	Connection cable for DI (digital inputs) and DO (digital outputs).....	25
5.2.2.4	Connection cable for AI (analogue inputs) and AO (analogue outputs).....	26
5.2.3	Potential equalization.....	26
5.2.4	Data transmission of signals.....	27
5.2.4.1	Profibus.....	27
5.2.4.2	Analogue outputs.....	28
5.2.5	Information on Cable and Lines Routing.....	28
5.2.6	Connection of analysis gas lines.....	29
5.2.6.1	Extraction Points for Analysis Gas.....	29
5.2.6.1.1	Gas extraction fitting unpressurized and up to 400 mbar.....	29
5.2.6.1.2	Gas extraction fitting up to 50bar.....	31
5.2.6.2	Laying of Analysis Gas Lines.....	33
5.2.6.3	Gas Inlets AwiFLEX.....	33
5.2.6.4	AwiSamplex - Measuring Point Switch-Over.....	35
5.2.6.5	Exhaust air - Discharge of the Measuring Gas.....	37
5.2.7	Installation of Humidity and Flow Sensor AwiFLOW.....	38
5.2.8	Initial Operation.....	40
6	Handling of the Gas Analysis System.....	41
6.1	Maintenance.....	41
6.1.1	Cleaning.....	41
6.1.2	Calibration.....	42
6.1.3	Hydrogen sulphide filter.....	42
6.1.4	Detonation Flame Arrester.....	42
6.1.5	Connecting Tubes.....	42
6.1.6	Condensate traps.....	43
6.2	Replacing a Fuse.....	43
6.2.1	Specification Fuse F1 (Input Voltage 100-240 VAC).....	43
6.2.2	Specification Fuse F2 (Power Supply Unit Output Voltage 24 VDC).....	43
6.3	Spare Parts List.....	43
6.4	Disposal.....	44
6.5	Product Liability.....	44
7	Technical Data and Sensor Accuracy.....	45
7.1	Technical Data.....	45
7.2	Accuracy, Service Life and Calibration of the Sensors.....	45
8	AwiDESULF combi-package for microbiological desulphurisation.....	48
8.1	Intended Usage.....	55

Table of Contents

8.2	Assumptions for Interpreting.....	55
8.3	Required Space.....	55
8.4	Mechanical Connection.....	57
8.5	Electrical Connection.....	58
8.6	Maintenance.....	59
8.6.1	Check non-return valve and solenoid valve.....	59
8.6.2	Procedure for checking the non-return valve and solenoid valve.....	59
9	AwiLAB Gas analysis.....	61
9.1	Required Space.....	62
9.2	Mechanical Connection.....	62
9.3	Electrical Connection.....	62
10	AwiVac.....	64
10.1	Required Space.....	65
10.2	Assemblies in the AwiVac.....	66
10.3	Mechanical Connection.....	67
10.4	Electrical Connection.....	68
11	AwiWarn.....	69
11.1	Installation AwiWarn.....	69
11.2	Required Space.....	70
11.3	Electrical Connection.....	71
11.4	Settings and calibration.....	72
12	Annex.....	73
12.1	Declarations of Conformity.....	73
12.1.1	CE Declaration of Conformity for Devices Not Intended to be Installed in an Ex-Zone.....	74
12.1.2	CE Declaration of Conformity for Devices Intended to be Installed in an Ex-Zone.....	75
12.1.3	UKCA Declaration of Conformity for Devices Not Intended to be Installed in an Ex-Zone.....	76
12.1.4	UKCA Declaration of Conformity for Devices Intended to be Installed in an Ex-Zone.....	77
12.1.5	IEC - Conformity Declaration.....	78
12.2	Certificat TÜV SÜD UL - CSA 61010-1-2012.....	80

1 Preface



PLEASE READ THE INSTRUCTION MANUAL AND SAFETY INSTRUCTIONS CAREFULLY BEFORE INSTALLATION AND OPERATION!

This Instruction Manual provides you with information to assist you in using the gas analysis system. The Instruction Manual is part of the product and has to be kept throughout the service life of the product. When subsequently passing on the gas analysis system to a third party, the customer has to provide the Instruction Manual along with it. The new owner of the system has to be trained in the regulations referred to. If you receive an amendment to the Instruction Manual at a later stage, this amendment is also part of the Instruction Manual.

The device may only be used in a technically perfect condition and for its intended use, with awareness of safety aspects and possible hazards and in full adherence with the Instruction Manual. Please operate and service your gas analysis system based on the information in this Instruction Manual.

The Instruction Manual for the Awite - Gas Analysis System consists of two parts:

Part A: Product Description, Installation and Operation

Part B: Operation

2 Identification

This Instruction Manual is intended for Awite Bioenergie GmbH gas analysis systems of the respective series specified on the cover sheet. The type plate on the right hand side panel of the device indicates the device type, the required voltage supply and the rated output.

The manufacturer's address is:

Awite Bioenergie GmbH
Grünseiboldsdorfer Weg 5
85416 Langenbach/Niederhummel, Germany

Phone: +49 8761 / 72 162 - 0

Fax: +49 8761 / 72 162 - 11

Email: info@awite.com

<http://www.awite.com>

3 Safety Instructions Part A

The device is only designed for situations of intended use. A non-intended use can lead to personal injury and property damage. Only use the device as intended.

The device measures combustible or explosive gases and is installed in their environment. There is a potential risk of spread or ignition of a hazardous atmosphere. Make sure to observe the rules regarding explosion protection.

Line breakage, breakage of fittings and damage inside and outside the unit can lead to explosion hazard and risk of poisoning. Regularly check pipes and fittings for changes (damage, corrosion, brittleness, leaks, animal damage) or have maintenance carried out. Replace if necessary (use only suitable materials and fittings).

Biogas contributes to the greenhouse effect and thus to climate change. If possible, do not discharge gas into the atmosphere.

Excessive rated pressure on the gas analysis system can cause gas to escape. During shutdown, when no gas is present at the sensors, the device can withstand a maximum of 2 bar overpressure up to the first valve. If the system pressure at the gas extraction points is reduced by the customer, it must be ensured that no more than 2 bar can reach the gas analysis system even in the event of a fault.

Parts inside the device are under electrical voltage. Danger to life by electric shock! ALL installation/repair/maintenance operations on the gas analysis system or on the whole plant must only be carried out in a de-energized state and when the system is completely turned off. Observe electrical safety regulations.

Biogas contains hydrogen sulphide. Gas leakage can lead to acute inhalation toxicity. At a concentration of hydrogen sulphide of more than 22,000 ppm or room volumes that are less than the standard container size (32 m³) or air exchange rates of less than once per hour, the risk of a possibly even deadly poisoning caused by hydrogen sulphide needs to be assessed individually and appropriate measures have to be taken. Avoid small room volumes and low air exchange rates.

Carbon monoxide is odorless and toxic. In the event of a fault, it can accumulate in the device and escape in a gush when it is opened. While opening the housing, ensure sufficient ventilation and distance or monitor the environment for carbon monoxide.

An improperly performed installation, electric installation, initial operation, or maintenance of the gas analysis system may cause hazards, especially due to gas and electrical current. These activities must therefore only be performed by trained personnel. The specialist personnel must have read and understood the Instruction Manual and follow its instructions.

Hydrogen sulphide is toxic. Watch out for smell of rotten eggs. Ventilate the room and do not enter.

Carbon monoxide is toxic. A suitable gas warning sensor must be used, unless the ventilation is sufficient.

The main switch serves as a mains disconnection facility to shut down the function and avoid hazards caused by electricity. The device has to be installed in such a way that the main switch operation is not impeded.

In case of a defect, gas leakage may occur. In case of insufficient ventilation, even small amounts can lead to a hazard (poisoning, explosion) over a longer period of time. The device must therefore not be installed in unvented shafts or poorly ventilated rooms.

Different electrical voltages may be present at the terminals in the terminal box. An incorrect connection will lead to malfunction and hazards arising from electrical current. For information on the allocation of the different terminals or the wiring in the terminal box please refer to the electric diagram provided as part of the system.

Combustible gas could enter the device through the exhaust gas line and create an explosive atmosphere there. Therefore, lead the exhaust lines separately and directly to the outside and have nothing discharge into the exhaust gas line. In case of analysis gas recovery, ensure the exhaust gas line is not longer than 20 m and have it lead the exhaust gas only into gas-bearing areas in which a maximum underpressure or overpressure of 20 mbar prevails.

Gas which may be toxic, flammable or explosive flows through the exhaust gas line. Therefore, the exhaust gas must not be released inside the building unless there is appropriately sufficient ventilation.

The device conveys combustible gas. A continuous stay in the immediate vicinity of the device may lead to a statistically increased risk of explosion. Therefore, no persons are allowed to stay permanently in the vicinity of the device.

To ensure the safe and correct operation of the process analysis system, regular maintenance work is an absolute necessity, as during this process wearing parts (such as seals) are replaced and the whole system is checked thoroughly. Failure to comply increases the risk by gas leakage (danger of explosion). The maintenance interval must therefore be observed.

The state of the gas analysis system must be checked on a regular basis, error messages need to be addressed. In the event of the error messages 'potentially dangerous atmosphere' or 'risk of explosion' as well as with loose hose ends, porous hoses or other leaks that lead to an explosion hazard, disconnect the device from the gas supply and shut it down. Contact Awite or an Awite contract partner.

The drain of the condensate trap is a secondary source of gas release. In case of poor ventilation, a hazardous explosive atmosphere may arise. Therefore please make absolutely sure to close the discharge tap after emptying the condensate traps.

The device contains fuses that are under electrical voltage. Danger to life by electric shock. Replace the fuses only in a non-energized state. Observe electrical safety regulations.

The measuring point switch-over includes a diffusion opening to prevent the occurrence of a dangerous atmosphere (explosion hazard) inside. Therefore check coarse dust filter for any dirt on a regular basis and clean it in order to maintain its function.

Leakages in the AwiCONTAINER may create a hazardous atmosphere. The ventilation grilles are important in order to dilute the air in case of leakages. These must not be closed.

Carbon monoxide is odorless and toxic. It can accumulate in the AwiCONTAINER. A poisoning can be deadly. With carbon monoxide-containing gas, install a suitable CO gas alarm sensor.

Leaking fuel gas mixture may cause an explosion hazard in the AwiCONTAINER. Install an electrocatalytic gas warning sensor, except for biogas with low leakage flow (pressure at sampling point max 20 mbar) or low flammable gas concentration (less than 4 % v/v).

Gas warning sensors can deliver too low readings or even become unusable due to hydrogen sulphide in the air. Calibrate gas warning sensors in according to manufacturer's recommendation (every 6 months). If the ambient air contains hydrogen sulphide, shorten the calibration interval (to 3 months).

Disconnecting the connection cable between the AwiLAB and the milligas counter or the drum gas meter, respectively, during operation may lead to faulty controls. This can cause excessive pressure in the connected collecting gas bags, which could then lead to damage and thus to gas leakage. Before conversion work, the gas analysis system must be de-energized.

AwiDESULF: In order to avoid gas leakage via the air supply line and thus a risk of explosion, a leakage test of the air supply line with non-return valve must be carried out after installation and initial operation of the system.

AwiDESULF PureOxygen: Pure oxygen can react explosively with oil and grease. Do not use lubricants and sealants containing oil or grease in pure oxygen or enriched air.

AwiDESULF: Hot surface on the compressor, thus risk of burns. Do not touch.

The gas analysis system contains icons with the following meaning:



Attention, General Hazard Point. Refer to the documentation. Disregarding this can lead to death or serious personal injuries or property damages.



Warning of dangerous electrical voltage.

Please also observe the safety instructions in Part B!

4 Product description

The following chapter contains information on the intended usage, the device category according to the ATEX classification, the ambient conditions during operation and storage as well as safety information.

4.1 Intended Usage

WARNING

The device is only designed for situations of intended use. A non-intended use can lead to personal injury and property damage. Only use the device as intended.

The gas analysis systems serve as analytical device for air, biogas, sewage gas, biomethane as well as hydrogen up to 100vol% and hydrogen sulphide up to 5vol%. They are neither part of explosion protection nor a warning device. They are used without any additional pressure reducing measures for measuring biogas with a maximum of 20 mbar of underpressure or overpressure. The suitability for use in safety-critical applications must be assessed by the user for each case. Reliability data can be provided by Awite if required.

WARNING

The device is installed in the vicinity of combustible or explosive gases. Operating a non-explosion-protected device in a hazardous atmosphere can cause an explosion with personal injury and property damage. Do not place the device in a dangerous atmosphere unless a corresponding marking exists on its housing.

4.2 Device Category According to ATEX Classification

Applies only within the EU and in countries in which the ATEX Directive (2014/34/EU) also applies. The ATEX marking is located on the left outside of the casing.

4.2.1 Device category not intended for installation in an Ex-zone



Marking per ATEX with

 II 2/- G IIA

Gas-carrying pipes with inflammable or explosive gas of explosion group IIA (e.g. biogas) may be connected to the device at the appropriate point (zone 2 or 1 in the interior of the line). The device itself has to be installed outside of a hazardous atmosphere.

4.2.2 Device category intended for installation in an Ex-zone 2

Marking per ATEX and IEC EN 60079 with

  II 2/3 G Ex nC ec IIA/IIC T1 Gc X

Gas pipes with combustible or explosive gas (zone 2 or 1 inside the pipe) may be attached to the device at the designated and appropriate place. The suitable detonation arrester must be used with gas IIB or IIC. The device itself may be installed in zone 2 gas IIC: Electrical connections must not be separated under voltage. The volume inside the device must be detected by means of a suitable warning sensor and the power circuits have to be disconnected from mains if necessary. The types of protection nC and ec refer to the outside of the display and the integrated terminal box respectively.

4.2.2.1 Safety device for monitoring the interior space

A gas warning sensor of the ignition protection type

 II 2G / EEx de IIC T4

for intended use as a safety or control device in order to detect methane / Zone 2 in accordance with the requirements of Directive 2014/34/EU, sections 1.5.5 through 1.5.8 is available at Awite.

4.3 Description of the Gas Analysis System and Dimensions

The gas analysis system is located inside a stainless-steel wall cabinet. The space requirement and list of the exterior and interior views are summarized in the table below. The cabinet is mounted to the wall using four wall clips (see illustration for dimensions). There needs to be enough room in front of the device for opening the door arrangement and for operating the device.

Table 1: Mounting Dimensions Gas Analysis System

Device type	Mounting dimensions [mm]		
	Width	Height	Depth
AwiFLEX	567	700	260

The analysis gas lines are routed to the system from the left hand side via the condensate traps for the manual emptying of the system. Pressure-resistant pipes are recommended as analysis gas lines:

- Diameter 4/6mm or 1/8"/1/4"
- Material: stainless steel 1.4401 or highly resistant plastic (depending on the site of operation, stainless steel pipes might be obligatory)

All connections on the condensate traps and on the gas analysis system are implemented as hose screw or pipe screw connections for these pipe cross-sections. For protection purposes, the analysis gas lines should be run through protective tubes.

Product description

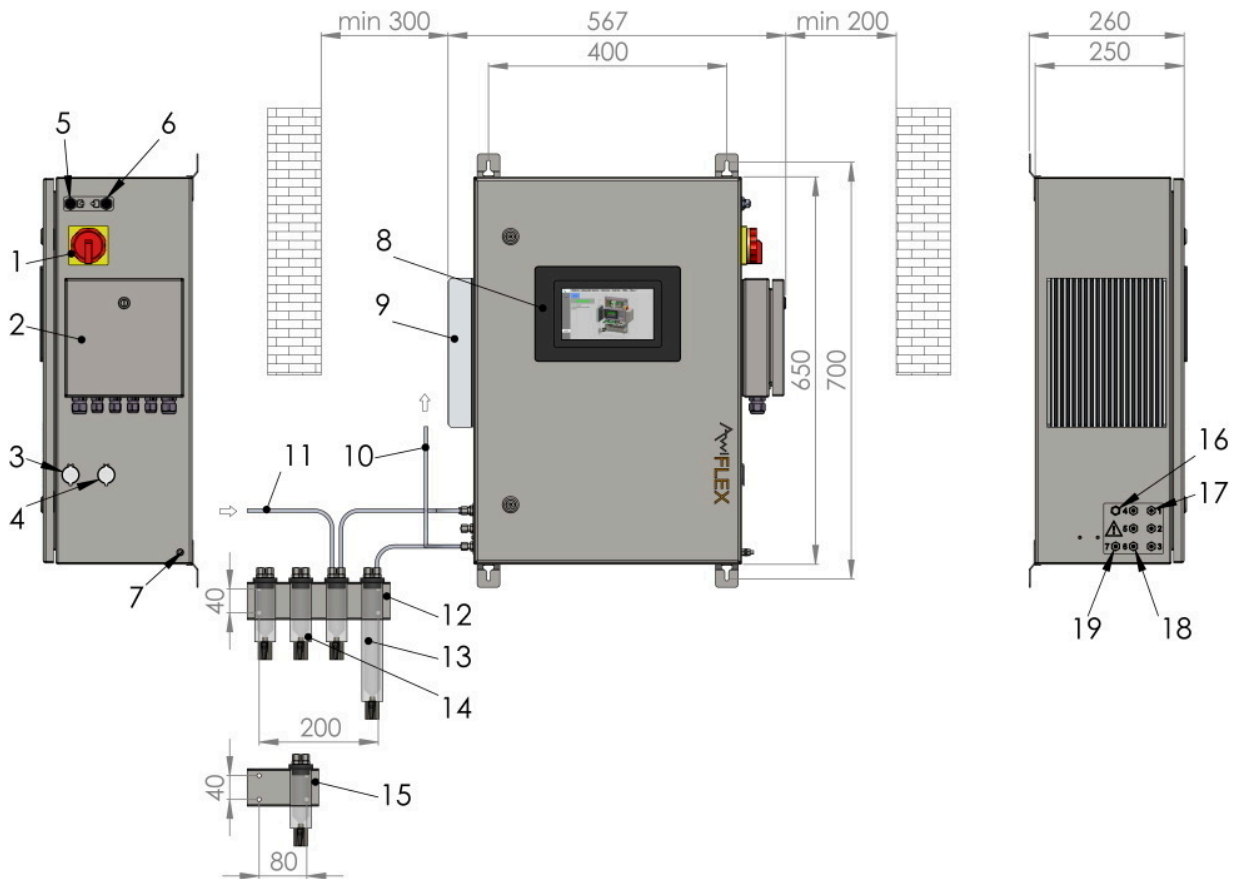

Figure 1: AwiFLEX including condensate traps on the outside

The equipment shown here serves as an example, as the components are individually assembled according to customer requirements.

- | | |
|---------------------------------|---|
| 1. Main switch | 11. External supply of analysis gas |
| 2. Terminal box | 12. Mounting brackets for 4 condensate traps |
| 3. USB connection | 13. Condensate container gas cooler |
| 4. RJ45 | 14. Condensate trap analysis gas |
| 5. Profibus IN | 15. Mounting brackets for 2 condensate traps |
| 6. Profibus OUT | 16. Supply of fresh air |
| 7. Potential equalization | 17. Connections for measuring points |
| 8. Panel PC | 18. Connection for exhaust air |
| 9. Measuring gas cooler AwiCool | 19. Connection for condensate from gas cooler |
| 10. Exhaust air | |

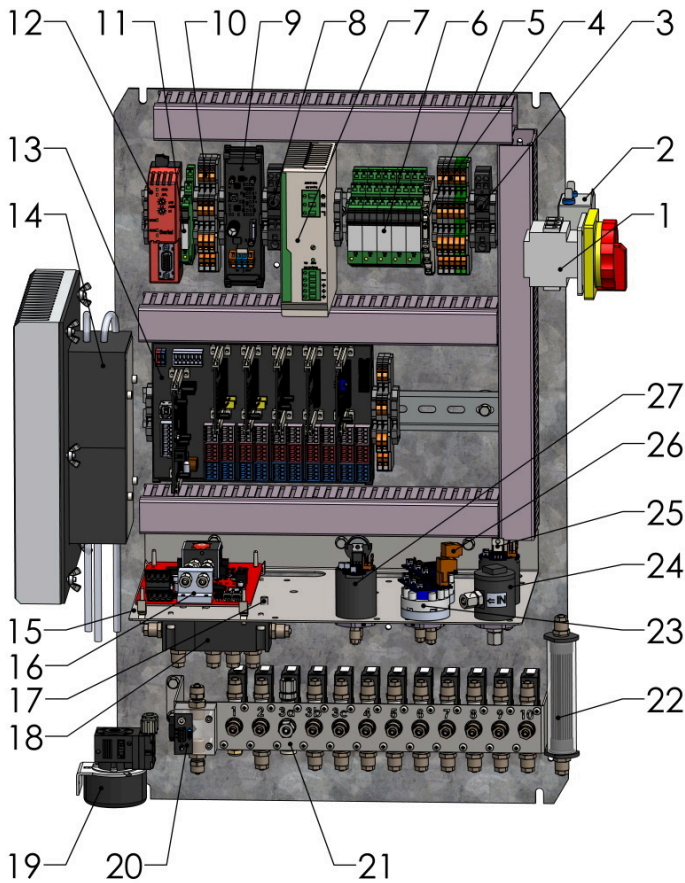

Figure 2: Assemblies in the AwifLEX gas analysis system.

The equipment shown here serves as an example, as the components are individually assembled according to customer requirements.

- | | |
|------------------------------------|--------------------------------------|
| 1. Main switch | 15. Mounting brackets sensors |
| 2. Line filter | 16. Multi-gas sensor InfraFRED |
| 3. Fuse terminal 100-240 VAC | 17. Temperature sensor |
| 4. Terminals 100-240 VAC | 18. Awiconnect incl. pressure sensor |
| 5. Relay feedback motor protection | 19. Membrane pump |
| 6. Relay Awidesulf | 20. Water sensor Awih ₂ O |
| 7. Power supply unit | 21. Valves |
| 8. Fuse terminal 24 VDC | 22. Hydrogen sulphide filter |
| 9. Awiprotect | 23. Hydrogen sensor |
| 10. Terminals 24 VDC | 24. Filter Awiclean |
| 11. Relay group error | 25. Oxygen sensor |
| 12. Profibus module | 26. Hydrogen sulphide sensor |
| 13. Awicore (PLC module) | 27. Carbon monoxide sensor |
| 14. Measuring gas cooler Awicool | |

4.4 Ambient Conditions and Limits for Operation and Storage

Although the Awite gas analysis systems are designed for use under rough conditions, some requirements concerning the location and environmental conditions should be met in order to obtain a high accuracy of measurement and to avoid damaging the system. For the conditions not listed here, the specifications from IEC Standard 60359 apply to application group 1.

4.4.1 Installation location

The system is intended for indoor use.

4.4.2 Installation height

The gas analysis system can be operated in areas which are located up to 2,000 m above sea level (normal height null, NHN).

4.4.3 Ambient Temperature

In the interior of the casing, the temperature can be 15 °C higher than the ambient temperature. Therefore, the ambient temperature for the device must be between +5 °C and +35 °C in order to guarantee an exact measurement of the sensors, not to damage the electronic components and to be able to operate the unit safely. The analysis systems are calibrated at 25°C. All detailed specifications refer to this temperature, any deviations that occur under significantly changed temperature conditions are sensor-related.

CAUTION

The temperature inside the device can be up to 15°C higher than the ambient temperature. Excessively high temperatures can lead to damage to components and reduce the service life of sensors. Sub-zero (°C) temperatures can destroy electrochemical sensors. This affects the measuring function and gas leakage can occur. Install the device in rooms with temperatures between +5°C and max. 35°C. The temperature in the control box must not exceed 50°C . Do not install the device in the hot exhaust air of cogeneration units.

4.4.4 Ambient humidity

The relative humidity must be kept between 0 and 80% .

4.4.5 Mains voltage fluctuations

Mains supply voltage fluctuations of up to $\pm 10\%$ of the nominal voltage are permissible.

4.4.6 Overvoltage category

Transient overvoltages are permissible up to the values of

OVERVOLTAGE CATEGORY II

These values for transient overvoltage are typical for devices that are supplied via the building installation.

4.4.7 Wetness and degree of pollution in the environment

The gas analysis system complies with protection class IP 54 and is therefore dust- and splash-proof, but is not intended for installation in wet environments.

The device is intended for installation in an environment with

POLLUTION DEGREE 2.

This is only non-conductive pollution, although temporary conductivity caused by dew may be occasionally expected.

4.4.8 Measuring gas pressure

The pressure in the measuring lines must be at atmospheric pressure ± 20 mbar (normal operation). Pressure outside this range is not allowed because the sensors may be damaged and measured values may be changed. With higher or lower pressure, corresponding measures must be taken (pressure regulator, precision pressure regulator, available from Awite).

NOTE

The highest rated overpressure inside the unit is 100 mbar in measuring mode and 2 bar in inactive state (valve inside the device closed). Therefore, in measuring mode the pressure is monitored and the device is stopped if 100 mbar is exceeded, in which case an error message is displayed.

4.4.9 Measuring gas, fresh air and exhaust air requirements

It has to be assured that no polluted flushing air or ambient air can be sucked in by the gas analysis system and that the exhaust air hose remains free and unobstructed at all times.

⚠ CAUTION

Water, particles and dirt can clog pipes, sensors and valves. As a result, monitoring functions and thus the measuring function can be impaired. Check the condensate traps daily.

When maintenance work is carried out on the gas pipe, the gas analysis system is to be switched off and the ball valve at the measuring gas extraction point has to be closed.

 **WARNING**

Work on the gas pipe may result in gas leakage. This creates a fire and explosion hazard. Switch off the device during maintenance work and close the ball valve during gas sampling.

4.5 Hazards from gas

As the systems are used for the analysis of biogas and in a biogas system environment, the explosion hazard has to be assessed prior to installation. A comprehensive risk assessment according to the machinery directive is available from Awite. Technical data can be adapted to new technological advances in the area of biogas by the manufacturer without any prior notice. Please contact Awite if you need information about possible additions to this Instruction Manual and whether it is the current version.

4.5.1 Zone division

Inside the measuring gas pipes and inside the gas analysis system there are only very small amounts of gas, whose volume is far below hazardous amounts. Therefore no Ex-zone obtains in this case. Whether there is an Ex-zone around the gas analysis system or its pipes or not depends on the probability of the occurrence of an explosive gas mixture. The following describes the actions to be taken to avoid an explosive atmosphere, which could arise due to the gas analysis system. If the following instructions are taken into account, there will be no Ex-zone inside the gas analysis system or the feed pipes either.

4.5.2 Flame or explosion propagation over gas bearing lines

With gases belonging to explosion group IIA (methane, biogas), tube and pipe connections with an internal diameter of 4mm have the same effect as a deflagration arrester (tested length of 11 cm). As the distance from the hose to the relevant ignition sources (sensors) is always less than 50 times the hose diameter, there is no need for separate deflagration arresters between the analysis device and gas-bearing lines with larger cross-section and hazardous atmosphere with the explosion group IIA and up to zone 1. There is an inspection report of an approved ATEX test centre verifying this.

When measuring hydrogen at higher concentrations¹ (special device); or with zone 0, a detonation arrester must be installed as needed.

¹ Biogas with up to 10% hydrogen in the flammable gas portion remains in explosion group IIA (source: BG ETEM/BAM research project Hydrogen Mixtures).

4.5.3 Leakage in the Measuring Gas Supply Line

A technically permanently leak-tight pipe is used. This is achieved by using a durable plastic tube or stainless-steel pipe and corrosion resistant screw connections with resistant sealing. Components like condensate traps that might be included in the measuring gas pipe also have screw connections. The pipes are technically permanently leak tight up to the first valve, which can be used to shut off the pipe.

4.5.4 Gas volume

The pipes (< 5m) and sensors inside the gas analysis system contain less than 0.05 l of gas. No risk of explosion results from this.

4.5.5 Leaks in the Gas Analysis System

Despite the slow reaction of methane with oxygen compared to other gases (55 bar*m/s compared to 550 or 1.415 bar*m/s with hydrogen and acetylene) at a similar maximum pressure (7.1 bar under normal conditions), the danger for persons at a control box volume of 60 l cannot be completely eliminated if only due to a deflagration, in the event that an explosive mixture would form inside due to a potentially occurring tightness error and a subsequent ignition due to unfavourable conditions or an escape of the gas from the gas analysis system.

The pipes inside are considered to be technically leak-tight. Due to the way they are constructed, some sensors can only be used with plug connections which are secured with spring terminals. As an additional safety measure, the high-quality methane sensor that is integrated in the gas analysis system is used to track down possible leaks. In case of a leakage, the first valve will cut off the supply of measuring gas. Each measuring channel is filled for a maximum of 120 s with measuring gas and is subsequently flushed with air for at least 60 s. As the air for flushing is sucked out of the inside of the gas analysis system, the composition of the air inside the device casing can be measured every 2 minutes. Fresh air flows from outside into the device casing via a sintered metal frit (air filter). Upon detection of > 1.0% of methane (= 20% LEL), all actuators will be shut down and the valve V1 cuts off the supply of measuring gas. Optionally, a potential-free contact is opened. Additionally, an error message is shown at the display. A potentially explosive atmosphere could thus be prevented behind valve V1 despite leakages. The gas path up to V1 is made with pressure-resistant pipes and clamp ring screw connections in a technically permanently leak-tight manner as described above.

For devices without methane sensor or with continuous methane measurement, safety is ensured by other means (e.g. reduced number of potential leakage points, see risk assessment).

4.5.6 Release of Potentially Toxic and Harmful Gases

The device itself releases no gases, only the gases contained in the measuring gas can be released. In accordance with its intended use, the device is used for the analysis of biogas and upgraded biogas and the gases contained therein may be released correspondingly.

Product description

In normal operation and when used as intended, these gases are not released. The risk of exposure hazards arising from release due to leaks is considered sufficiently low according to risk assessment.

5 Preparing the Gas Analysis System for Use

WARNING

This is a complex measuring and control system. Incorrectly performed installation, electrical installation, initial operation, or maintenance can lead to hazards and possibly even to death due to electric shock or risk of explosion. The respective work on the gas analysis system may therefore only be performed by trained professional personnel. The specialist personnel must have read and understood the Instruction Manual and follow its instructions.

5.1 Transport and Storage

This gas analysis system must be protected against impermissible loads or damages by, for example, humidity, vibration or shock. In the event of mechanical defects with electrical or electronic components, the gas analysis system must not be put into operation. The same environmental conditions as those for the operation apply to a possible storage of the gas analysis system before installation and commissioning.

5.2 Installation

The installation must be performed only by qualified personnel. They must be well familiar with the contents of this manual and any other provided manuals and repair instructions as well as with the safety instructions and specifications on the devices. In addition, the applicable national, local and system-specific regulations and provisions must be considered. An over-voltage protector must also be provided for by the operator.

The dimensioning of the gas analysis system can be found Fig. 1 in the chapter 4.3 . Unused inlets on the device casing have to be leak-proofed and closing elements have to be screwed in tightly. The device must not be installed in unvented shafts or poorly ventilated rooms. There must be enough space around the device so that the door of the casing can be opened and the device can be operated and controlled easily. For devices with a cooler, there has to be enough space for the circulation of air around the heat sink (at least 30cm).

CAUTION

In the event of a malfunction, the device can be brought into a safe state by de-energizing it. The device therefore has to be installed in such a way that the main switch operation is not impeded.

 **WARNING**

In the course of normal operation, small amounts of gas may escape through diffusion. If leakage occurs, the contents of the calibration gas bottles can escape quickly and gas can be accumulated via sample gas lines in accordance with gas pressure. In such cases and with small rooms and low air exchange, a dangerous atmosphere with a risk of poisoning and explosion may arise. Therefore, never mount the device in unventilated shafts.

5.2.1 Main Switch Mains Disconnection Facility

The main switch functions as mains disconnection facility.

5.2.2 Terminal boxes for electrical connections

 **DANGER**

Dangerous electrical voltage is present at the terminals in the terminal box and the cables fed. An incorrect connection may lead to electrical hazards and even death. For information on the allocation of the different terminals and the wiring in the terminal box, please refer to the electric diagram provided as part of the system. Check the connections afterwards.

The Awite gas analysis system includes a terminal box for external connection.

The terminal box offers connections for the following components:

- Power supply 100-240 VAC
- Group error
- Alarm outputs
- Analogue outputs
- Additional external sensor systems
- AwiSamplex - Measuring Point Switch-Over
- AwiDESULF - Combi-package for Microbiological Desulphurization

 **CAUTION**

Incorrectly dimensioned cables can lead to fire and electrical hazards. Use only cables as specified.

5.2.2.1 Terminal Boxes AwiFLEX

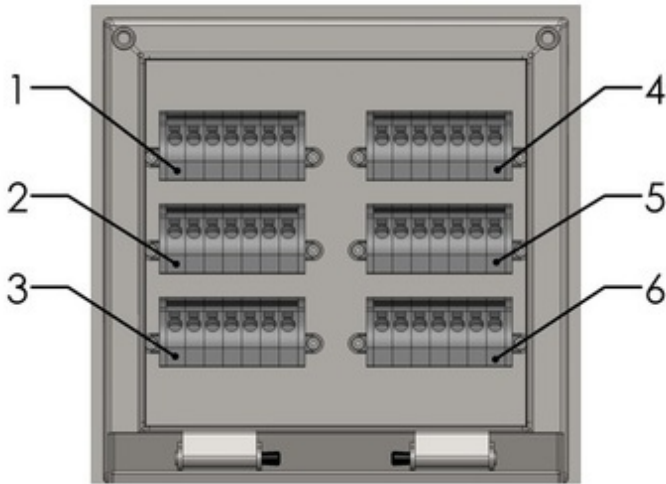

Figure 3: Terminal box Gas Analysis System AwiFLEX

The terminal box illustrated here serves as an example only, as the number of feed-through terminals depends on the respective system setup.

- | | |
|-----------------------------|-----------------------------|
| 1. Conductor connection X11 | 4. Conductor connection X14 |
| 2. Conductor connection X12 | 5. Conductor connection X15 |
| 3. Conductor connection X13 | 6. Conductor connection X16 |

5.2.2.2 Connection Cable 100-240 V for Power Supply

3-pin (3 x 1.5²) feed line 100-240 V

Specifications Connection Cable:

- AWG16 (metric equivalent 1.5mm²)
- 75°C / copper wire only (75°C / copper)

5.2.2.3 Connection cable for DI (digital inputs) and DO (digital outputs)

Specifications Connection Cable:

- AWG19 (metric equivalent 0.75mm²)
- 75°C / copper wire only (75°C / copper)
- shielded

5.2.2.4 Connection cable for AI (analogue inputs) and AO (analogue outputs)

Specifications Connection Cable:

- AWG21 (metric equivalent 0.5mm²)
- 75°C / copper wire only (75°C / copper)
- shielded / twisted in pairs

5.2.3 Potential equalization

The gas analysis system must be grounded. A screw (M6) is provided on the right-hand outer side of the stainless steel housing for connecting the grounding cable. The grounding cable must have a cross section of at least 6mm² (AWG 10).

WARNING

A non-connected grounding can lead to undefined voltages and electric shock. To unload voltages, connect the potential equalization to the provided connections with the defined cross-section.

5.2.4 Data transmission of signals

There are various possibilities for data transmission. If the connection to the process control is done via a bus connection (e.g. Ethernet, Profibus DP, serial interface), the corresponding interface is found on the right hand side of the device casing.

5.2.4.1 Profibus

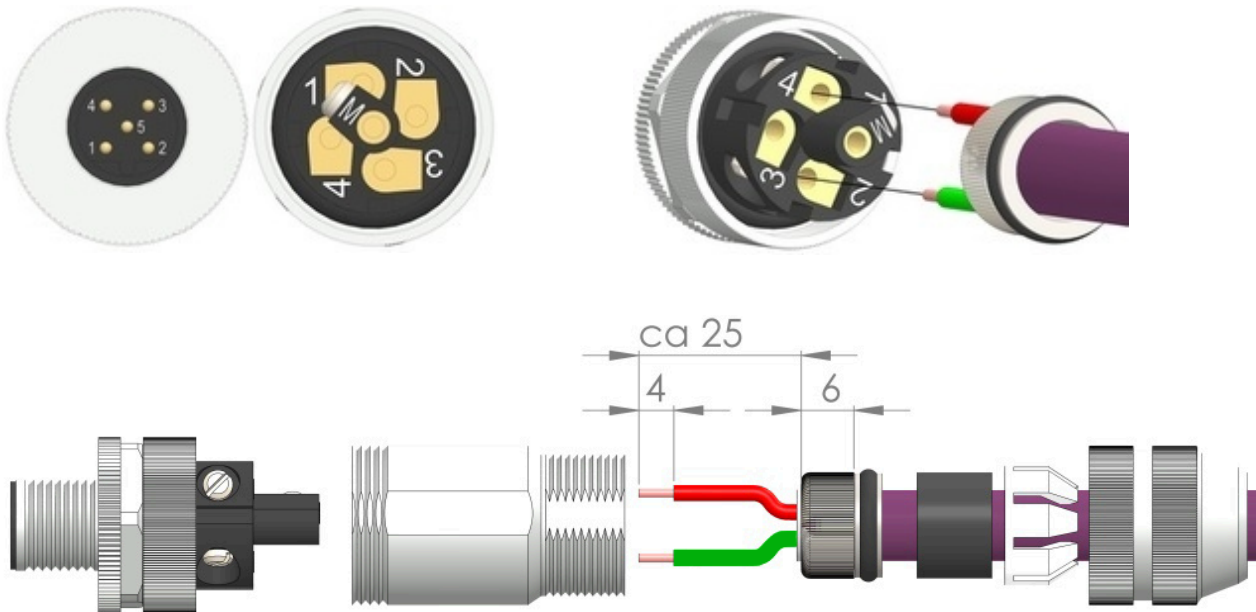

Figure 4: Pin allocation Profibus Connector

- Pin 1 -
- Pin 2 - RxD/TxD-N
- Pin 3 -
- Pin 4 - RxD/TxD-P

**For Profibus, please ensure that you are using the correct settings for the terminating resistor!
Mating connectors are supplied with the system.**

Operation of the gas analysis system as part of a Profibus system (terminating resistor set to OFF):

- Left plug > Connection from Profibus IN
- Right plug > Connection from Profibus OUT
- Set terminating resistor to OFF (see below)

Operation of the gas analysis system as a terminal device (terminating resistor set to ON):

- Left plug > Connection from Profibus
- Switch terminal resistance ON (see next point)

Set terminating resistance ON/OFF:

- Open device door
- Pull connector from Profibus module (see Fig. 1)
- Set switch on connector to ON/OFF.
- Plug connector back into Profibus module, tighten safety screws, close device door

5.2.4.2 Analogue outputs

The voltage supply for the analogue outputs takes place via the gas analysis system. A galvanic separation of the potentials at the recipient's end is necessary. Signals are exchanged by default in the range of 4...20 mA. The division of the value range for each measured quantity corresponds to the measuring range of the respective sensor. Signals outside the range of values have the following meaning:

- 0 mA = no signal
- 2 mA = Measured value incorrect
- 21 mA = Sensor overload

For information on the wiring of the analogue outputs in the terminal box please refer to the electric diagram. If more than 8 measured values are transmitted, the outputs in the terminal box can be allocated several times. The values are then transmitted alternately at intervals. The intervals are marked with potential-free markers.

5.2.5 Information on Cable and Lines Routing

Please note the following for the on-site running of cables:

- Use shielded lines for all signals
- Implement shield on one side on-site
- Separate laying of data and power cables.

5.2.6 Connection of analysis gas lines

As a matter of principle, the following applies: When carrying out maintenance work on the gas line, the gas analysis system must be turned off and the ball valve at the measuring gas extraction point has to be closed off. The connections for the gas lines can be found on the left hand side on the outside of the system. For the corresponding gas inlets, there are hose screw connections for flexible pressure-resistant plastic tubes (4/6mm or 1/8" / 1/4") optionally pipe screw connections for stainless steel lines (6mm or 1/4"). The exhaust air and condensate lines are also connected by hose screw or pipe screw connections. Fig. 8 show the allocation of the gas inlets.

5.2.6.1 Extraction Points for Analysis Gas

The analysis gas is usually taken directly from the process gas line of the respective measuring point. In order to achieve meaningful measurement results, care must be taken to ensure that the gas flow is arranged in a sensible manner and that dead spaces are avoided. If possible, the fitting sleeve (Rp 1/2') should be mounted on the upper side of the gas-carrying pipe or on the side so that no condensate can permanently flow into the analysis gas lines. By no means should an extraction point be located at the bottom half of a gas pipe.

The design type of the gas extraction fitting depends on the relative overpressure at the respective extraction points.

DANGER

Excessive rated pressure on the gas analysis system can cause gas to escape. During shutdown, when no gas is present at the sensors, the device can withstand a maximum of 2 bar overpressure up to the first valve. If the system pressure at the gas extraction points is reduced by the customer, it must be ensured that no more than 2 bar can reach the gas analysis system even in the event of a fault.

5.2.6.1.1 Gas extraction fitting unpressurized and up to 400 mbar

Different designs are used depending on the system pressure from -20mbar to 400mbar relative overpressure:

- Type 'Fitting for gas extraction unpressurized'
from -20mbar to 20mbar relative overpressure
without precision pressure regulator
- Type 'Fitting for gas extraction 400mbar'
from 20mbar to 400mbar relative overpressure
with precision pressure regulator

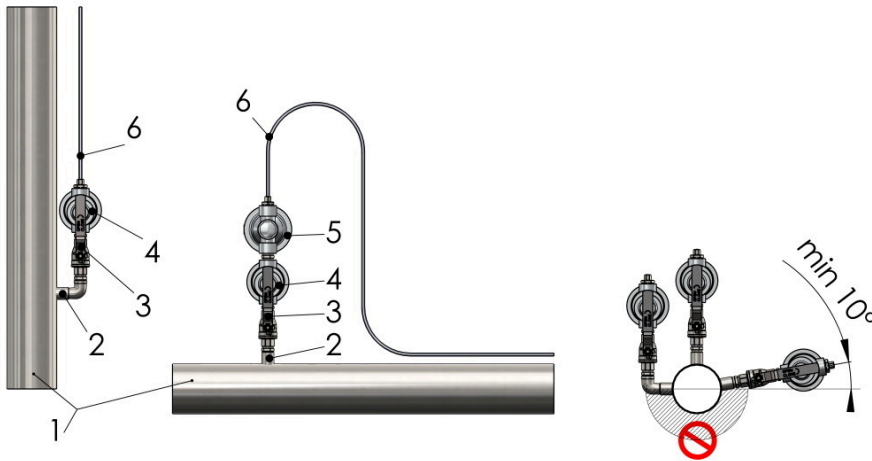

Figure 5: Gas extraction point on the top part of a gas line with ball valve and gas filter

- | | |
|-----------------------------|--|
| 1. Biogas line | 4. Gas filter |
| 2. Fitting sleeve (Rp 1/2") | 5. Precision pressure regulator |
| 3. Ball valve (R 1/2") | 6. Measuring gas pipe to gas analysis system |

Please take into account the following important points when designing and setting up the extraction points:

Connection: R 1/2" on the ball valve

Shut-off: A ball valve is fitted to the extraction point as the first component so as to allow closing off the line.

Filtering: Each gas extraction point is fitted with a particle filter behind the ball valve. This filter also allows a condensation of the gas before the analysis gas pipe in cold ambient temperatures.

Precision pressure regulator: If the system pressure at the extraction point exceeds 20 mbar of relative high pressure, then additional precision pressure regulators have to be used (provided by Awite) which produce a stable output pressure of approx. 5 mbar of relative high pressure at a maximum of 400 mbar of relative high pressure at input.

The analysis gas pipes are conducted from the extraction points to the condensate traps in front of the gas analysis system (Fig. 6).

Preparing the Gas Analysis System for Use

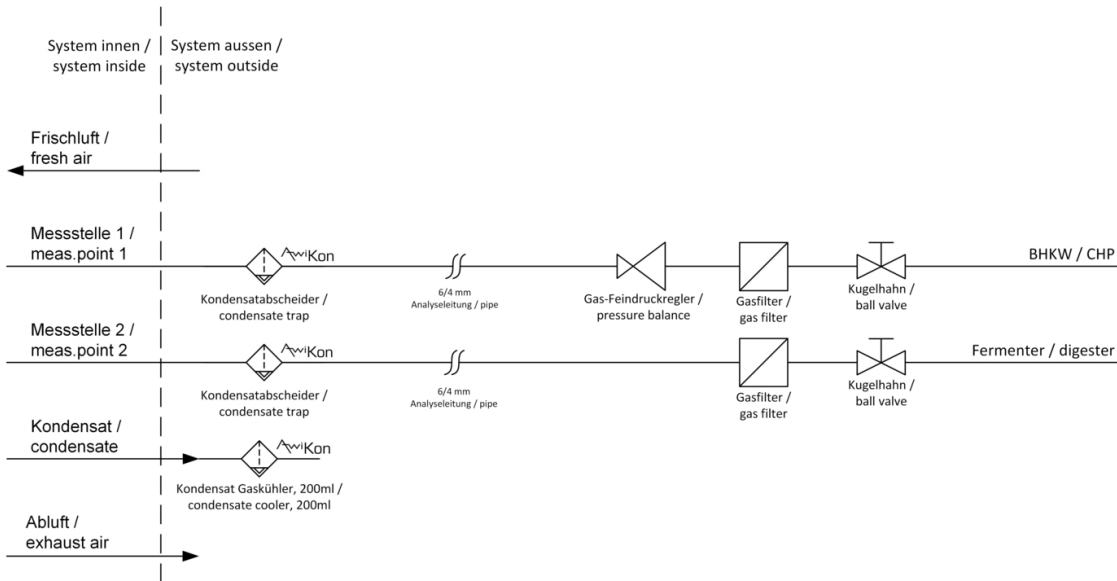

Figure 6: Schematic layout of the extraction points for analysis gas - Exemplary representation

5.2.6.1.2 Gas extraction fitting up to 50bar

For gas extraction from pipes with system pressures between 400mbar and 50bar relative overpressure, the gas extraction fitting 50bar is used. The fitting is designed for indoor installation.

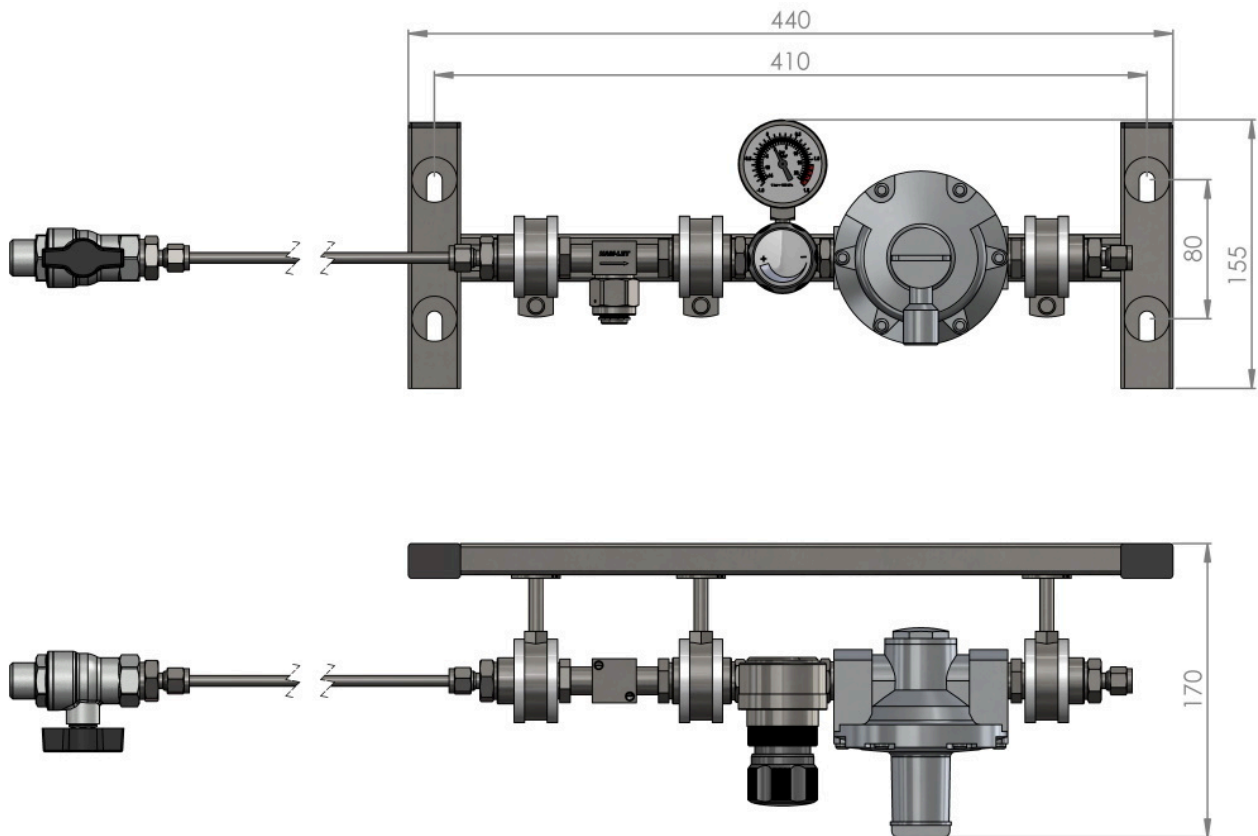

Figure 7: Gas extraction fitting 50bar with particle filter (optional)

Please take into account the following important points when designing and setting up the extraction points:

Type: Depending on the condition of the gas to be extracted, the gas extraction fitting 50bar must be configured in different versions:

Version for corrosive gases

- From dew point and relative moisture $rm \geq 95\%$
- H₂S content does not have to be taken into account

Version with additional particle filter

- From particle size $<40\mu\text{m}$

Connection to process line: By means of a ball valve R1/2". Pay attention to mounting it in the upper part of the pipe. The ball valve is the first component that allows shutting off the pipe.

Connection of the gas extraction fitting 50bar: The gas extraction fitting 50bar is connected to the ball valve via a 6mm VA pipe or a pressure-resistant 6/4mm hose. The equipment for both versions is included in the scope of delivery.

Pressure reducer gas extraction fitting 50bar: The first component after the optional particle filter is an adjustable pressure reducer. The outlet pressure must always be set to **200 mbar** here.

Installation position gas sampling fitting 50bar: The second component after the adjustable pressure reducer is a precision pressure regulator. To ensure trouble-free operation of the precision pressure regulator, the installation position of the gas extraction fitting 50bar must be observed. If the fitting is mounted horizontally, it should not be mounted overhead (on the ceiling). Vertical mounting is also possible if the gas flow is from the bottom to the top.

⚠ WARNING

If the presetting of the pressure reducer is too high, malfunctioning of the gas extraction fitting 50bar may occur. The outlet pressure here must always remain set to 200mbar.

5.2.6.2 Laying of Analysis Gas Lines

- Line material: Resistant plastic (4 /6 mm or 1/8" / 1/4") or stainless steel (6 mm or 1/4"), pressure resistant
- Do not insulate pipes
- From the gas extraction point, lay the first 12 m of the analysis gas pipe with an upward gradient
- Run in shield tubes, cable lines etc. to the gas analysis system
- Pipe lengths: Up to 100 m of suction length possible with the given cross-sections (variable suction times)
- Run the pipes in a way that makes it possible to replace them after several years.

5.2.6.3 Gas Inlets AwiFLEX

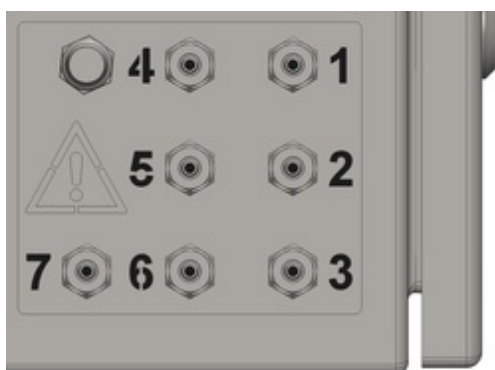

Figure 8: Allocation of gas inlets, exhaust air and condensate outlet with AwiFLEX

Connection no.	Description
1	Connection to measuring point 1 or optionally connection to measuring point switch-over when there are more than 4 measuring points
2 (optional)	Connection to measuring point 2

Preparing the Gas Analysis System for Use

Connection no.	Description
3 (optional)	Connection to measuring point 3
4 (optional)	Connection to measuring point 4
5 (optional)	Calibration Gas Connection
6	Exhaust air connection: Exhaust air has to be led out of the gas analysis system into the open. When laying pipes outside make sure that the exhaust pipe can't freeze up (use a thicker line and plastic sleeve during the transition to the outside).
7	Condensate line from measuring gas cooler AwiCool

5.2.6.4 AwiSamplex - Measuring Point Switch-Over

If the measuring gas connections on the gas analysis device are not sufficient, a measuring point switch-over (Fig. 9, Fig. 10) must be integrated into the gas analysis system.

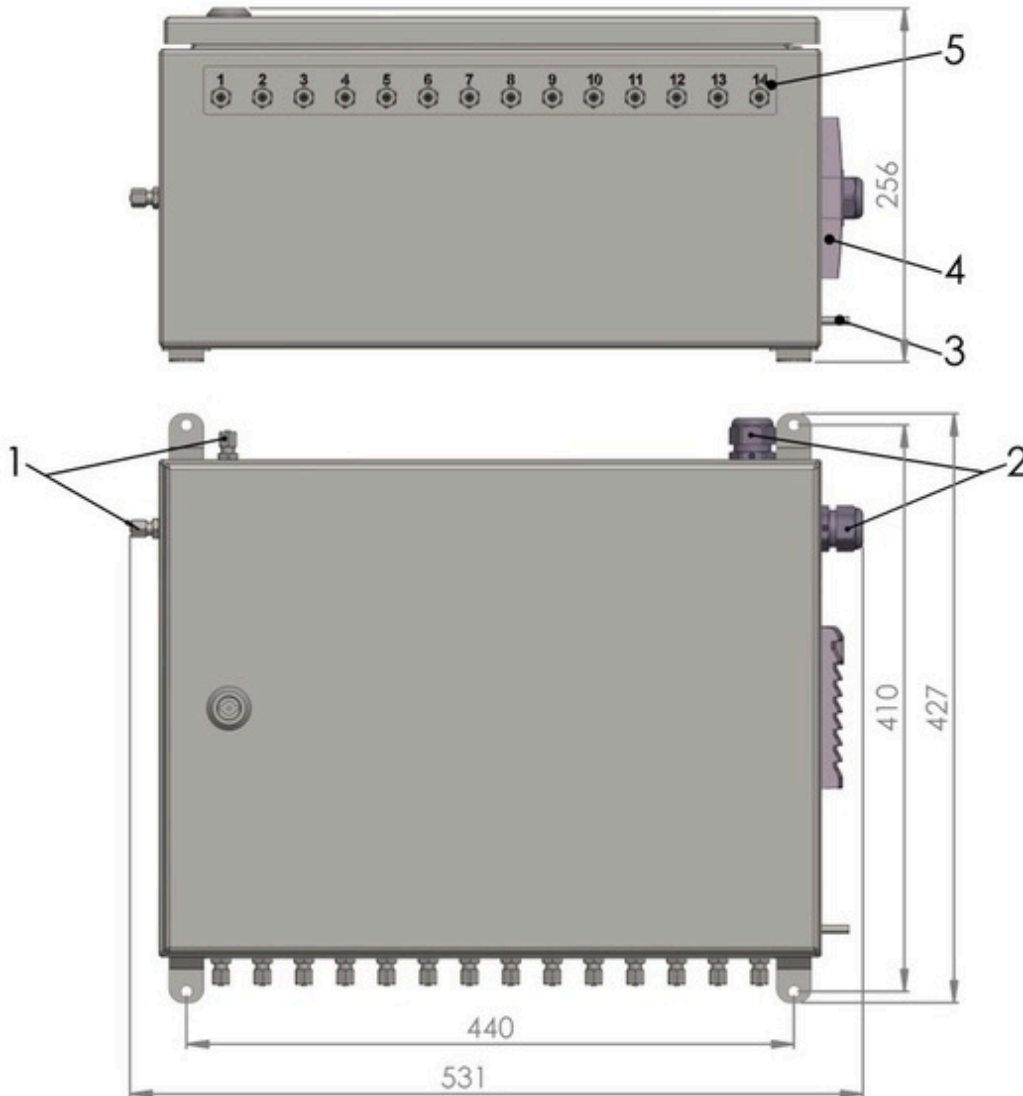

Figure 9: Measuring point switch-over for up to 14 measuring points

1. Measuring point outlet to gas analysis system (optionally on top or on the side)
2. Control (triggering) of valves from gas analysis system (optionally on top or on the side)
3. Potential equalization
4. Coarse dust filter
5. Measuring point inlets

⚠ CAUTION

Electrical voltage is present in the measuring point switch-over. A water ingress may cause a short circuit. Install the measuring point switch-over in such a way that the casing cannot be flooded via the diffusion orifice.

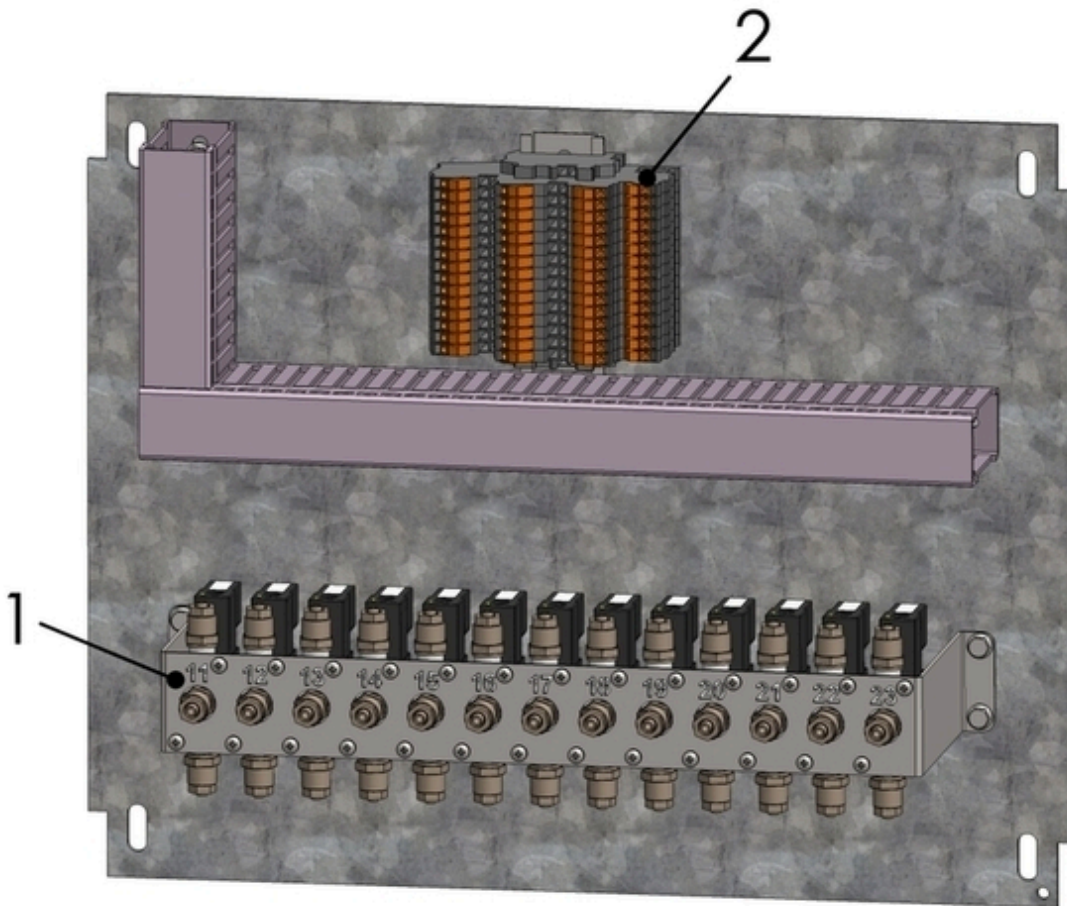

Figure 10: Components in the measuring point switch-over

1. Valves
2. Terminals

5.2.6.5 Exhaust air - Discharge of the Measuring Gas

The discharge of the measuring gas from the installation room of the gas analysis system occurs via a technically permanently leak-tight pipe, normally into the open environment, as the gas amount is very low. The pump that sucks out the gas has a capacity of approx. 0.7 l/min. About 2 l of biogas are sucked in per measuring point (max. 2 times per hour). Higher gas flow rates may occur with gas analysis systems that perform continuous measurements. One or more connections for the exhaust line are provided on the gas analysis system (hose screw or pipe screw connection). If several exhaust lines are provided, then these must not be combined in order to prevent the measuring gas from being pushed back into the device. When the discharge reaches the open, a hose with an internal diameter of at least 8mm has to be used. The exhaust gas line is run through the wall in a plastic protective tube which points down in a 90 degree angle at the outside of the wall (Fig. 11). This makes sure that no condensate accumulates in the duct, which could lead to blockage by freezing in winter. The customer must prepare a corresponding feed through the wall above the gas analysis system (diameter of approx. 25mm).

⚠ CAUTION

The exhaust gas may be combustible and toxic. This may lead to fire, explosion and poisoning. Do not release the exhaust inside the building unless an appropriate controlled ventilation facility exists.

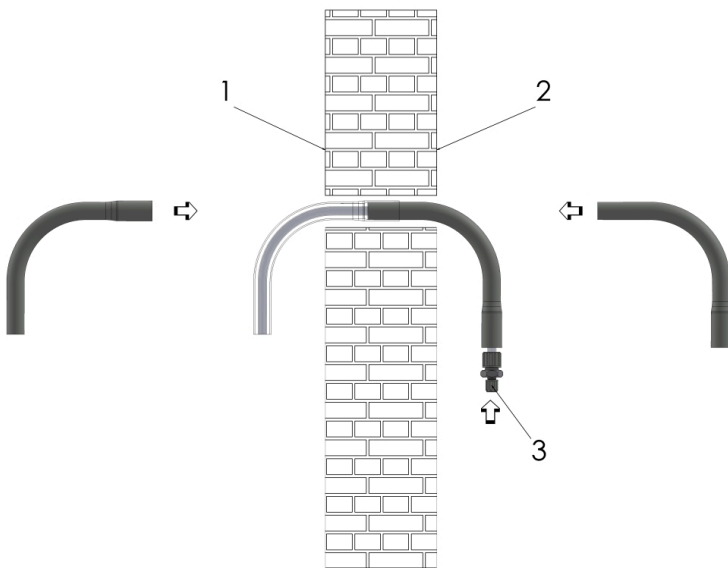

Figure 11: Installation of the exhaust pipe

1. Wall outer side
2. Wall interior side
3. Exhaust pipe from gas analysis system

⚠ DANGER

The device measures/rinses alternately with measuring gas and ambient air. Combustible gas could enter the device through the exhaust gas line. This creates an explosion hazard. Therefore, lead the exhaust gas lines separately to the outside and have nothing discharge into the exhaust gas line. You may only lead exhaust gas into gas-bearing areas (additional valve which only opens the path to the point of discharge during operation of the gas pump) if the exhaust gas line is not longer than 20 m and a maximum underpressure or overpressure of 20 mbar prevails in the gas-bearing area. When introducing exhaust gas into gas-bearing lines, the possibility of the formation of an explosive atmosphere due to admixed air must be taken into account. Either feed into an Ex-Zone 1 or into an area where the gas flows continuously.

5.2.7 Installation of Humidity and Flow Sensor AwiFLOW

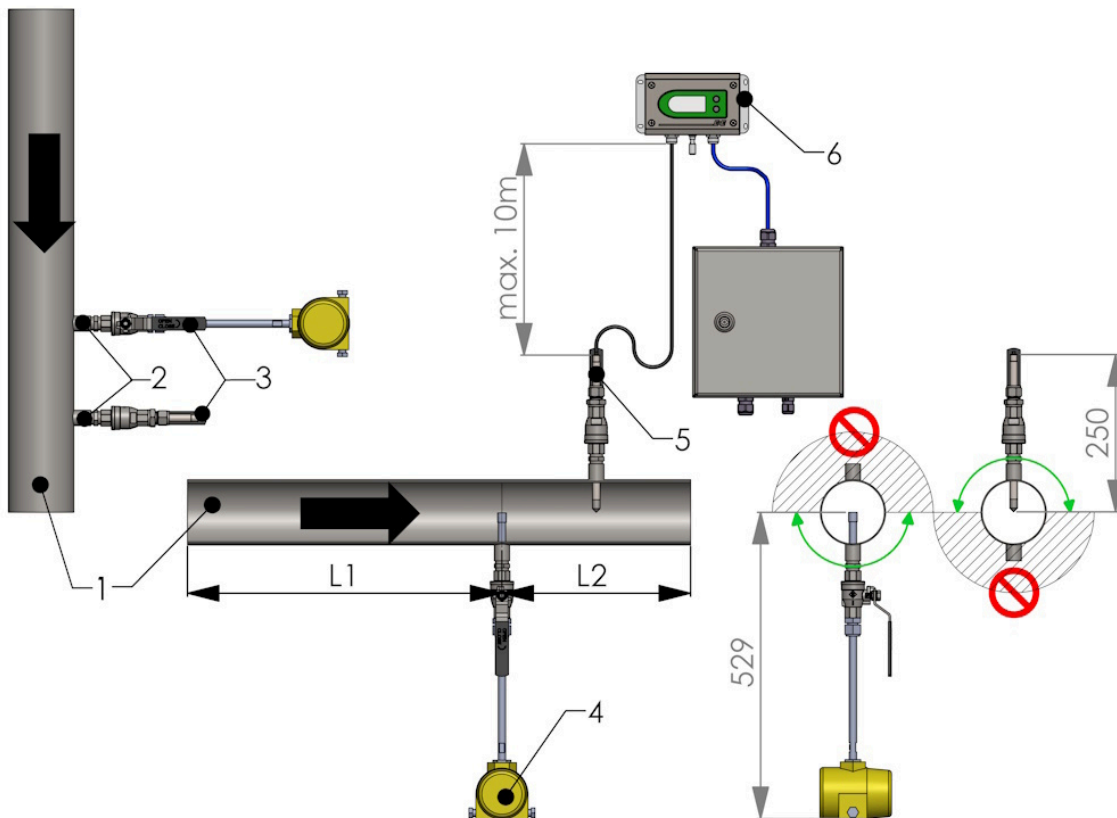

Figure 12: Installation of humidity and flow sensor AwiFLOW with alignment

- | | |
|---|---|
| 1. Gas pipe | 5. Humidity sensor incl. temperature sensor |
| 2. Fitting sleeve (Rp 1/2") | 6. Evaluation unit with display for humidity sensor |
| 3. Ball valve (R 1/2") | L1 Inlet section (Upstream) |
| 4. Flow sensor incl. temperature sensor | L2 Outlet section |

When installing the AwiFLOW humidity and flow sensor, please observe the notes on alignment in Fig. 12 .

The humidity sensor is connected to an external terminal box of the gas analysis system via an evaluation unit. The distance between sensor and the evaluation unit must not exceed 10 m .

When installing the AwiFLOW flow sensor, the inlet and outlet sections listed below without fittings or bends have to be adhered to (Tab. 2). Failure to observe these distances can have a significant effect on the measuring accuracy, so that the installation of a flow conditioner may be necessary. For details and prices please contact Awite. There must also be sufficient space (approx. 650mm from the pipe) for installation or removal of the sensor. The sensor should be positioned in such a way that the measuring tips are centered in the pipe, the flow direction arrow points in the flow direction of the gas, and the flattenings on the sensor shaft are parallel to the pipeline. After connecting the cable, make sure that all fastenings are tightened and that the sensor cover is secured against opening by means of the grub screw.

Note Tab. 2 and Fig. 13 **the information given is a recommendation and is based on well-founded series of measurements. But there is always the possibility of changed circumstances, which might require other factors. Therefore Awite shall not be liable for any deviations of the flow profiles.**

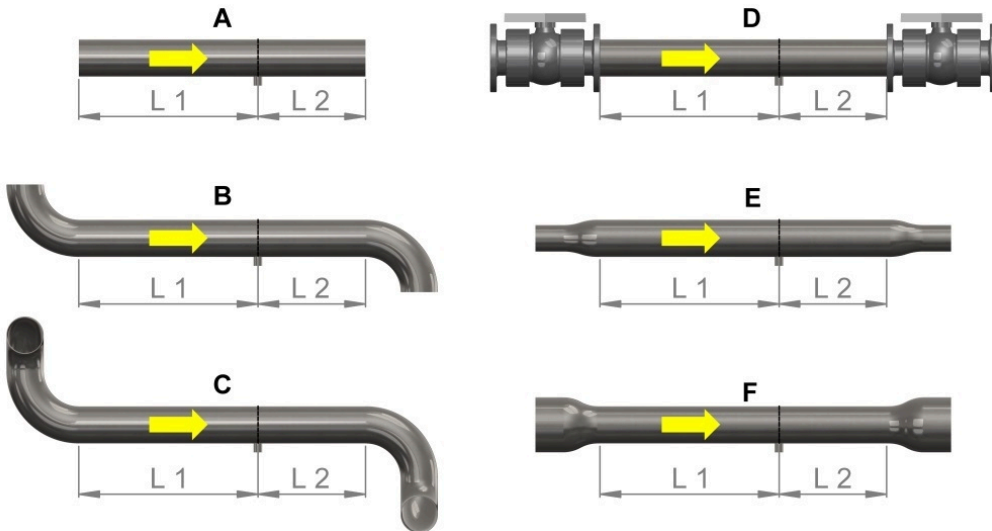

Figure 13: Inlet and Outlet Sections Flow Sensor AwiFLOW

Table 2: Recommendations for Installing an AwiFLOW Flow Sensor

Standard Recommendation for Straight Pipeline with Undefined Pipe Routing			
Pipe inner diameter	Inlet section L1	Outlet section L2	Illustration
< 150mm	20 x pipe Ø	10 x pipe Ø	Fig. 13 (A)
>= 150mm	15 x pipe Ø	7.5 x pipe Ø	
with flow conditioner	6 x pipe Ø	2 x pipe Ø	

Recommendation for 45° or 90° angle on one level			
< 150mm	15 x pipe Ø	7.5 x pipe Ø	Fig. 13 (B)
>= 150mm	10 x pipe Ø	5 x pipe Ø	
with flow conditioner	6 x pipe Ø	1 x pipe Ø	
Recommendation for 45° or 90° angle on two levels			
< 150mm	20 x pipe Ø	10 x pipe Ø	Fig. 13 (C)
>= 150mm	15 x pipe Ø	5 x pipe Ø	
with flow conditioner	6 x pipe Ø	2 x pipe Ø	
Recommendation for a Flow Control Valve in the Inlet or Outlet Section			
< 150mm	20 x pipe Ø	10 x pipe Ø	Fig. 13 (D)
>= 150mm	15 x pipe Ø	5 x pipe Ø	
with flow conditioner	9 x pipe Ø	2 x pipe Ø	
Recommendation for a Setup with an Extension in the Inlet or Outlet Section			
< 150mm	20 x pipe Ø	10 x pipe Ø	Fig. 13 (E)
>= 150mm	15 x pipe Ø	5 x pipe Ø	
with flow conditioner	9 x pipe Ø	2 x pipe Ø	
Recommendation for a Setup with a Reduction in the Inlet or Outlet Section			
< 150mm	15 x pipe Ø	5 x pipe Ø	Fig. 13 (F)
>= 150mm	10 x pipe Ø	3 x pipe Ø	
with flow conditioner	6 x pipe Ø	1 x pipe Ø	

5.2.8 Initial Operation

Prior to the initial operation of the gas analysis system, it needs to be checked whether the operating conditions comply with the guidelines provided in this manual. When starting up the process analysis system, the following points have to be noted:

- The gas analysis system has to be fully installed and connected.
- Start up the gas analysis system only in an acclimatized state.
- Connect the appropriate gas analysis systems to the main power supply and use the main switch to turn them on.

6 Handling of the Gas Analysis System

The gas analysis system may only be operated by personnel who have been authorized and instructed by the operator of the system. The instructions of this Instruction Manual have to be strictly adhered to. The state of the device has to be checked on a regular basis and error messages need to be addressed. Do not stay in the vicinity of a system in operation for prolonged periods of time. Refer to Part B of the Instruction Manual for more information on the operation of the system.

CAUTION

The risk assessment is based on a maximum stay of 100 hours per year directly at the device. A longer length of stay increases the risk due to the arising of a dangerous atmosphere and explosion inside the device as well as due to toxic gas. Therefore, no persons are allowed to stay permanently in the vicinity of the device.

6.1 Maintenance

For the safety of the gas analysis system, regular maintenance work is an absolute necessity, as during this process wearing parts (such as seals) are replaced and the whole system is checked thoroughly. In order to maintain the warranty, a first maintenance and calibration service is required within the first 10 months, thereafter every 12 months at the latest as a rule. Depending on measuring requirements, it might also be necessary to service the system every 6 months or less. Maintenance work may only be carried out by qualified personnel and the maintenance intervals must be adhered to. The state of the gas analysis system must be checked on a regular basis, error messages need to be addressed.

WARNING

Wear of parts can lead to leakage and malfunction. This may even cause an explosion. Wear parts must be replaced regularly. Check the device regularly and have the recommended maintenance performed regularly.

In case of alarm outputs with an additional service switch, the service switch must be turned off again after maintenance. For further information, please refer to the electric diagram.

WARNING

A bridged service switch prevents the transmission of alarms. As a result, facility-specific hazards may arise. Turn the service switch off again after completion of maintenance.

6.1.1 Cleaning

The display screen may only be cleaned with suitable cleaning agents and cleaning cloths. The casing may only be cleaned with acid-free cleaning agents. The gas cooler has to be cleaned on a regular basis

in order to guarantee a smooth and error free operation. Only expert personnel is allowed to clean the inside of the casing and the gas-bearing lines and components so that the operational safety is not jeopardized.

CAUTION

The measuring point switch-over has a filter which ensures the gas exchange with the environment and thus prevents a dangerous atmosphere inside. In the case of soiling, its function is impaired. Clean the filter regularly.

6.1.2 Calibration

The calibration intervals depend on the sensors being used, the composition of the measuring gas and the measuring interval. Normally, after the initial check of the system, one calibration per year is sufficient. If you require a higher accuracy of results, or in case of heavy use, a calibration interval of 3-6 months is recommended.

The calibration can be carried out directly on-site by Awite or an Awite partner. Please contact Awite for further information.

6.1.3 Hydrogen sulphide filter

A hydrogen sulphide filter is implemented in devices that are fitted with a hydrogen sensor. For these gas analysis systems, the colour of the filling needs to be checked. The unused filling material is black. A grey or white colouring is an indication that the filter needs to be changed. Awite offers replacement filters or refills. The replacement is done by AWITE in the course of the maintenance work. However, the filter has to be replaced after 12 months at the latest and independent of the colouring.

6.1.4 Detonation Flame Arrester

A detonation flame arrester is not necessary as the distance of the tubes to the ignition sources is correspondingly small. As the tubes are very small in diameter, they act as a deflagration flame arrester. The type examination certificate is available from Awite on request.

6.1.5 Connecting Tubes

The gas analysis lines between the condensate traps and the gas analysis system are to be checked on a regular basis for condensation discharges. There must be no condensate in the feeding tubes from the condensate traps to the gas analysis system, as this can cause disruptions and defects in the gas analysis system.

6.1.6 Condensate traps

The condensate traps are installed in the measuring gas supply line to the gas analysis system for each measuring point. Condensate that might accumulate inside the line is collected in the container. After a regular visual check (daily), the condensate must be emptied manually.

WARNING

An opened condensate trap leads to leakage of gas. This creates a danger of poisoning and explosion. Close the discharge tap after emptying the condensate traps.

6.2 Replacing a Fuse

WARNING

Electrical voltage is present at the fuse slots. Danger due to electric shock! Prior to replacing fuses, you must turn off the main switch and thereby disconnect the gas analysis system from the main power supply.

The fuses are located in the fuse terminals F1 (100-240 V) and F2 (24 VDC).

6.2.1 Specification Fuse F1 (Input Voltage 100-240 VAC)

Standard: IEC/EN 60127 - 2/2

Type: 5 x 20mm

Designation: F 10A L 250VAC

6.2.2 Specification Fuse F2 (Power Supply Unit Output Voltage 24 VDC)

Standard: IEC/EN 60127 - 2/2

Type: 5 x 20mm

Designation: F 5A L 250VAC

6.3 Spare Parts List

The operating safety of the gas analysis system can only be maintained by using original parts or approved spare parts for every repair operation that is carried out and by adhering closely to the instructions in this manual and the repair instructions. Spare parts lists are available at Awite.

6.4 Disposal

The symbol indicates that the product should not be discarded as unsorted waste but must be sent to separate collection facilities for recovery and recycling.

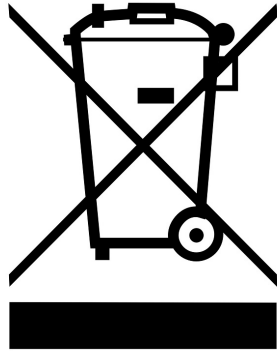

For a small fee, Awite is prepared to take back any Awite devices that need to be disposed of and use them for further industrial processing.

6.5 Product Liability

Awite does not assume liability for damages caused by faulty measuring values.

Please take notice of the General Terms and Conditions (AGB), which are available in their current version at www.awite.de/Agb.

7 Technical Data and Sensor Accuracy

7.1 Technical Data

For technical data, please refer to the provided data sheets.

7.2 Accuracy, Service Life and Calibration of the Sensors

A warranty of 12 months including the electro-chemical sensors can only be guaranteed under the accurate adherence of the surrounding conditions. Although all electrochemical sensors are equipped with a software overload safety stop, damages due to concentrations (hydrogen sulphide and hydrogen) that exceed the upper measuring range value over a longer time-span cannot be ruled out. So please take this into account when choosing the sensor. If concentrations are too high, we cannot give any warranty, as this might result in an excessive wear of the sensors. The life-span warranty applies to a minimal measuring interval of 30 minutes for a measurement at one measuring point, which means a maximum of 48 measurements per day. In case of several measuring points, the number of measurements is reduced accordingly. Through the use of an air adjustment (calibration with fresh air), the zero points of the sensors can be aligned. In this case the oxygen sensor is adjusted to 21% in ambient air. An overview of the factors affecting the measurement accuracy can be found in Tab. 3.

From these figures it is possible to calculate the measurement uncertainties based on the uncertainty of the calibration gases, the calibration intervals, and the ambient temperature.

If you're interested in receiving more comprehensive material on measurement uncertainty or on terms from IEC Standard 61207, we will be happy to provide them.

Table 3: Measuring uncertainties without uncertainty of the calibration gas. The uncertainty was determined at the calibration point. Values that have been conservatively extrapolated to the measuring range end value are indicated in brackets (worst case)

Measured component	physical unit	Calibration point (measuring range end value)	Standard uncertainty u2 at delivery +/- 10°C	Standard uncertainty u3 after 1 year +/- 10°C	Standard uncertainty u4 right after calibration +/- 0°C
Methane	Vol.-% CH ₄	97 (100)	0.1 (0.11)	1.5 (1,6)	0.03 (0.03)
		55 (100)	0.1 (0.2)	1 (2)	0.03 (0.05)
		2.5 (100)	0.1 (4)	0.4 (16)	0.03 (1.2)
Carbon dioxide	Vol.-% CO ₂	97 (100)	0.15 (0.15)	2.4 (2.5)	0.11 (0.11)
		45 (100)	0.11 (0.24)	0.9 (3)	0.04 (0.2)
		3 (100)	0.1 (3)	0.14 (5)	0.004 (0.3)
Oxygen elec-trochem.	Vol.-% O ₂	1 (25)	0.05 (0.9)	0.11 (1.5)	0.025 (0.6)
		21 (25)	0.8 (0,9)	1.3 (1.5)	0.1 (0.12)
Hydrogen-sulphide	Vol.-ppm H ₂ S	10 (20)	0.6 (1.2)	1 (2)	0.5 (1)
		170 (200)	6 (7)	15 (17)	2.5 (2.9)
		170 (500)	8 (24)	16 (50)	6 (18)
		1000 (1500)	30 (50)	90 (130)	10 (15)
		1000 (3000)	30 (90)	90 (260)	10 (30)
		1000 (5000)	30 (170)	90 (400)	15 (80)
		1000 (10000)	40 (400)	90 (900)	20 (200)
Hydrogen elec-trochem.	Vol.-ppm H ₂	1000	30	90	10
		2000 (5000)	60 (160)	170 (400)	20 (50)
	Vol.-% H ₂	3 (5)	0.1 (0.17)	0.26 (0.4)	0.05 (0.08)
		15 (25)	0.5 (0.8)	1.3 (2.2)	0.2 (0.3)
		100	3	9	0.7
Hydrogen WLD	Vol.-% H ₂	100	0.5	1.1	0.2
		95 (100)	0.9 (1)	1.4 (1,4)	0.8 (0.8)

Technical Data and Sensor Accuracy

Measured component	physical unit	Calibration point (measuring range end value)	Standard uncertainty u2 at delivery +/- 10°C	Standard uncertainty u3 after 1 year +/- 10°C	Standard uncertainty u4 right after calibration +/- 0°C
		33 (100)	1.3 (4)	1.6 (5)	0.8 (2.4)
Carbon monoxide electro-chem.	Vol.-ppm CO	1500 (2000)	50 (70)	160 (210)	20 (27)
Carbon monoxide infrared	vol% CO	100	1.3	1.6	0.8
Nitrogen calculated	Vol.-% N ₂	10 (78)	1.3 (4)	2.3 (7)	0.8 (2.5)
in case of different calibration gas composition:					
Methane	Vol.-% CH ₄	55 (100)	0.1 (0.19)	1 (1.8)	0.03 (0.05)

8 AwiDESULF combi-package for microbiological desulphurisation

The below illustration shows the exemplary setup of the combined combi-package for microbiological desulphurisation and the components supplied along with it. Via the suction filter, the ambient air is sucked in by the compressor and fed into the biogas system. The air is blown into the biogas system via the magnetic valves and the non-return valves. The non-return valves are spring-closed. The electric connection for the compressor incl. motor protection switch is located in a terminal box. The valves are controlled directly from the Awite gas analysis system.

⚠ CAUTION

AwiDESULF: Hot surface on the compressor, thus risk of burns. Do not touch.

In the AwiDESULF PureOxygen version, the compressor is replaced by a container with pure oxygen or by O₂ generators.

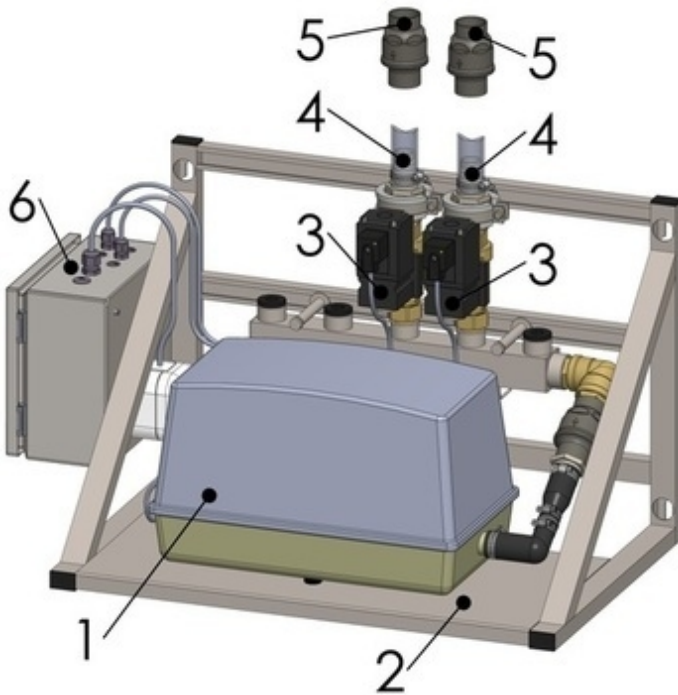

Figure 14: Schematic setup of AwiDESULF 100 - Exemplary representation

- | | |
|---|------------------------|
| 1. Compressor | 4. Outlet to fermenter |
| 2. Bracket compressor | 5. Non-return valves |
| 3. Magnetic valve, closed in a de-energized state | 6. Terminal box |

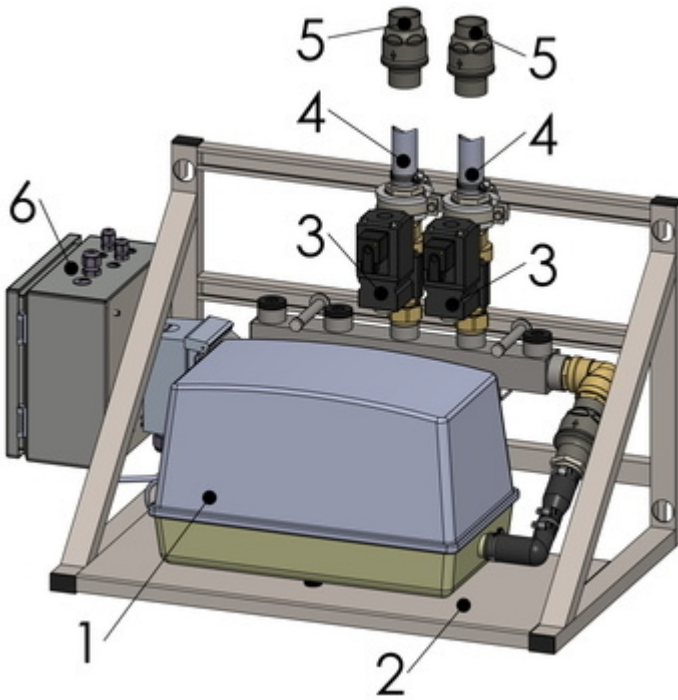

Figure 15: Schematic setup of AwiDESULF 100 UL/CSA - Exemplary representation

- | | |
|---|------------------------|
| 1. Compressor | 4. Outlet to fermenter |
| 2. Bracket compressor | 5. Non-return valves |
| 3. Magnetic valve, closed in a de-energized state | 6. Terminal box |

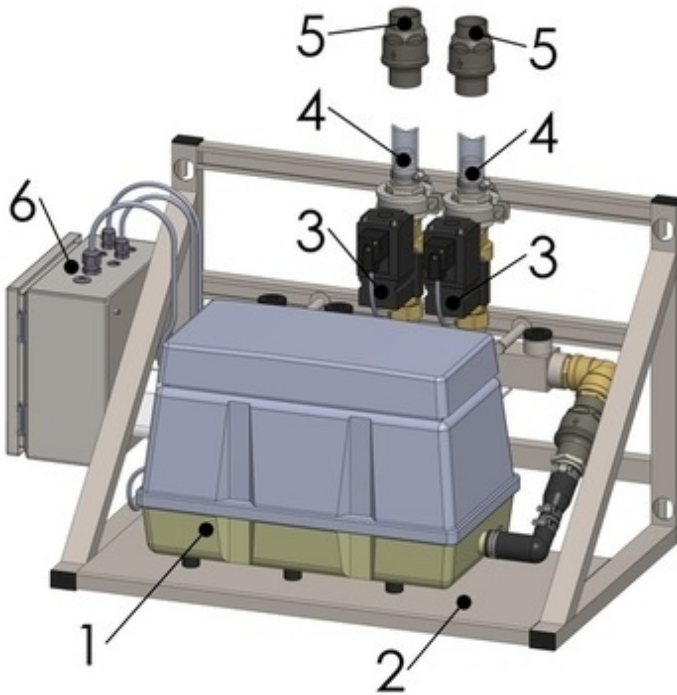

Figure 16: Schematic setup of AwiDESULF 200 - Exemplary representation

- | | |
|---|------------------------|
| 1. Compressor | 4. Outlet to fermenter |
| 2. Bracket compressor | 5. Non-return valves |
| 3. Magnetic valve, closed in a de-energized state | 6. Terminal box |

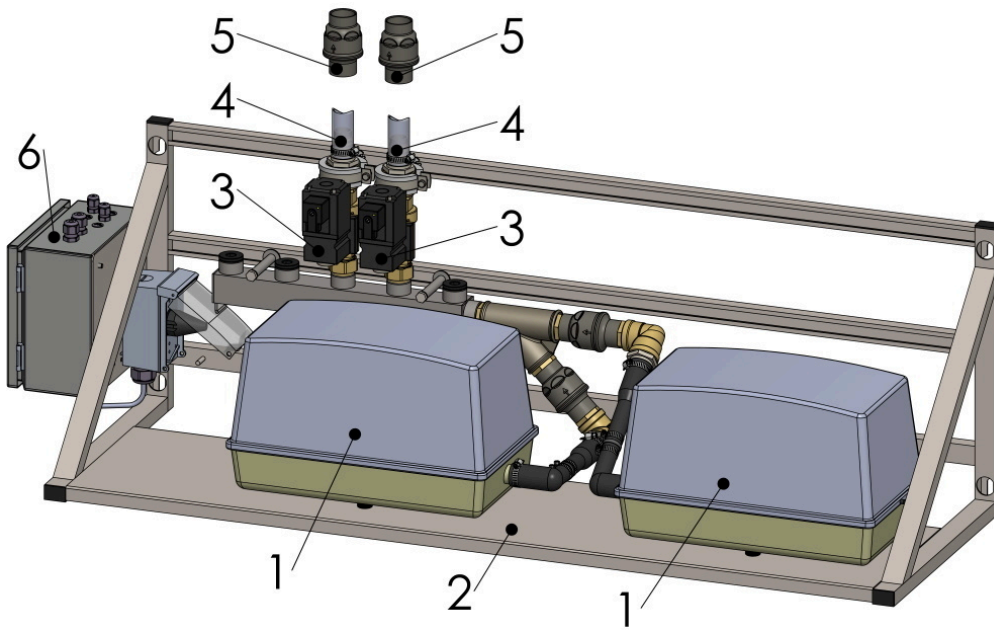

Figure 17: Schematic setup of AwiDESULF 200 UL/CSA - Exemplary representation

- | | |
|---|------------------------|
| 1. Compressor | 4. Outlet to fermenter |
| 2. Bracket compressor | 5. Non-return valves |
| 3. Magnetic valve, closed in a de-energized state | 6. Terminal box |

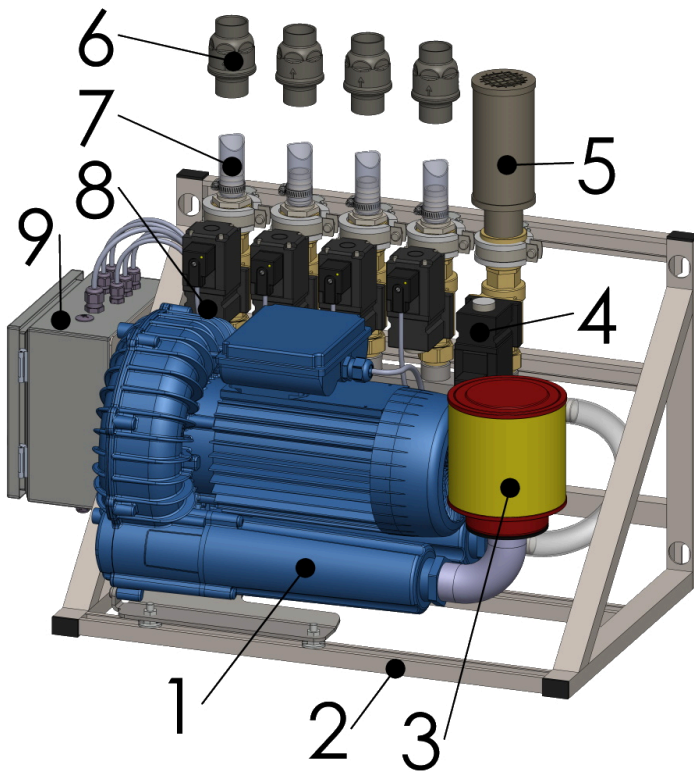

Figure 18: Schematic setup of AwiDESULF 300/500 - Exemplary representation

- | | |
|---|---|
| 1. Compressor | 6. Outlet to fermenter |
| 2. Bracket compressor | 7. Magnetic valve, closed in a de-energized state |
| 3. Air intake/filter | 8. Terminal box with motor protection switch |
| 4. Magnetic valve, open in a de-energized state | 9. Non-return valves |
| 5. Exhaust air | |

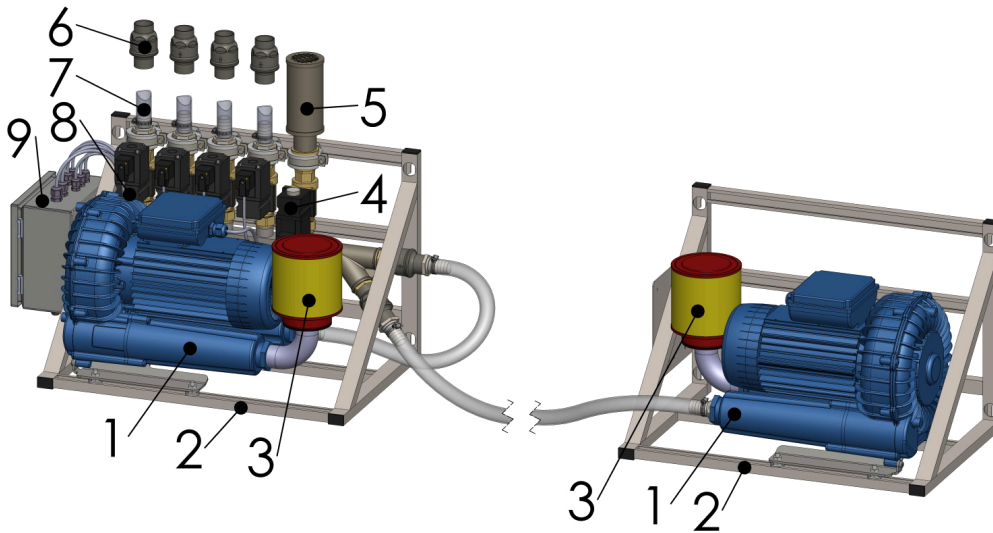

Figure 19: Schematic setup of AwiDESULF 1000 - Exemplary representation

- | | |
|---|---|
| 1. Compressor | 6. Outlet to fermenter |
| 2. Bracket compressor | 7. Magnetic valve, closed in a de-energized state |
| 3. Air intake/filter | 8. Terminal box with motor protection switch |
| 4. Magnetic valve, open in a de-energized state | 9. Non-return valves |
| 5. Exhaust air | |

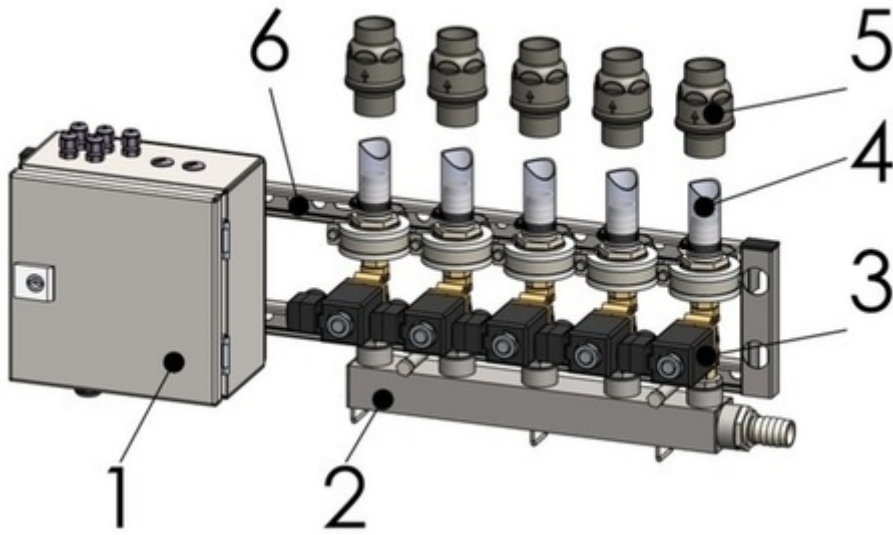

Figure 20: Schematic setup of AwiDESULF PureOxygen - Exemplary representation

- | | |
|---|------------------------|
| 1. Terminal box | 4. Outlet to fermenter |
| 2. Connection pure oxygen | 5. Non-return valves |
| 3. Magnetic valve, closed in a de-energized state | 6. Console |

8.1 Intended Usage

The combi package AwiDESULF serves to add air and pure oxygen to the biogas in order to thus achieve desulphurisation. The use for extraction or as an air ventilation system is not allowed.

8.2 Assumptions for Interpreting

The microbiological desulphurisation is used in biogas and sewage plants. The operator of the system is responsible for the division into zones based on the ATEX Directive and/or IEC 60079-10 and the risk assessment. With respect to the risk posed by a hazardous atmosphere per the ATEX Directive, the following assumptions for the medium 'air' form the basis of the interpretation:

- Installation location: no zone
- Interior space of fermenter: Zone 2
- Check valve to solenoid valve(s): Zone 2
- Interior space of compressor to valves: no zone
- Max. reachable pressure with compressor: < 500 mbar

An exemplary risk assessment for the addition of pure oxygen and air is available from Awite on request.

8.3 Required Space

For information on the required space, please refer to the following illustrations. For details on the functioning of the desulphurisation unit, please refer to Part B of the Instruction Manual.

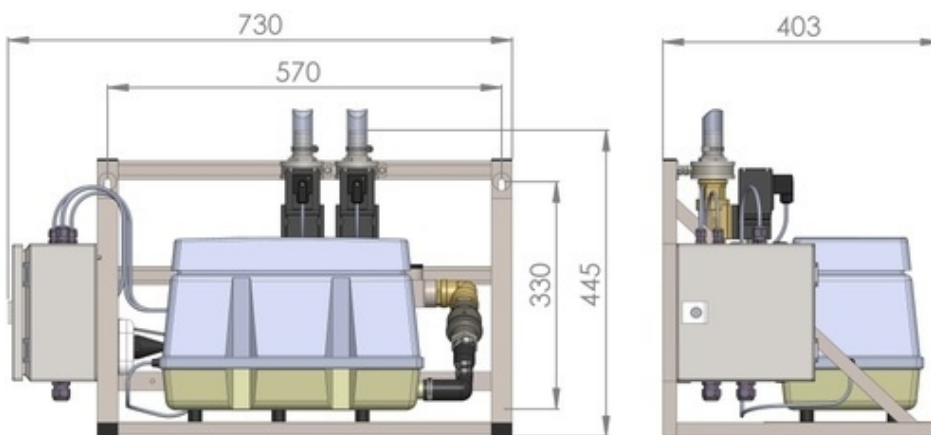

Figure 21: Required space for AwiDESULF 100, AwiDESULF 100 UL/CSA and AwiDESULF 200 - Exemplary representation

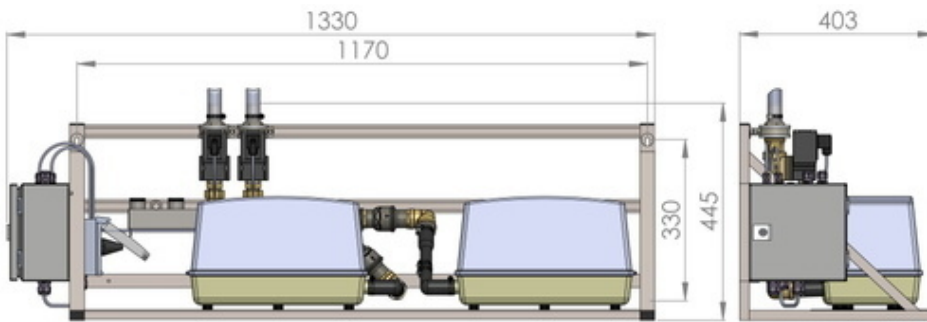

Figure 22: Required space for AwiDESULF 200 UL/CSA - Exemplary representation

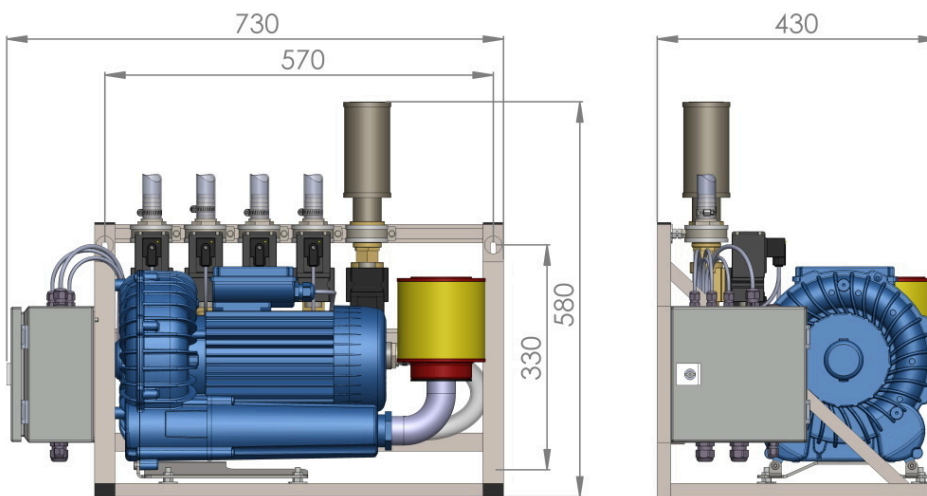

Figure 23: Required space for AwiDESULF 300/500 - Exemplary representation

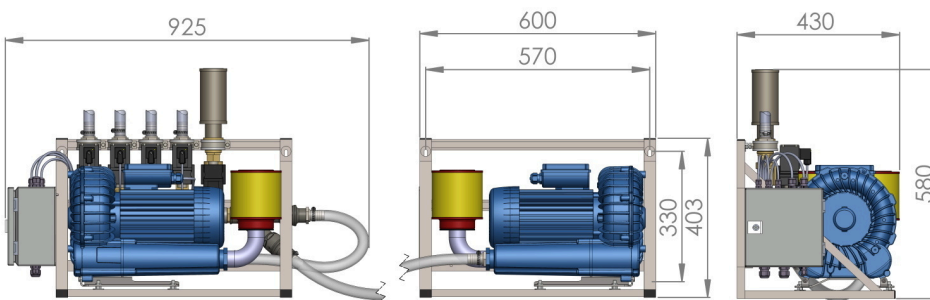

Figure 24: Required space for AwiDESULF 1000 - Exemplary representation

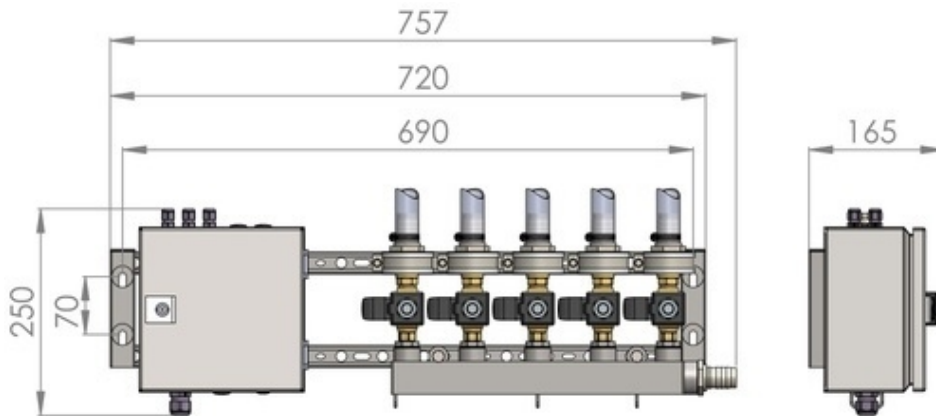

Figure 25: Required space for AwIDESULF PureOxygen - Exemplary representation

8.4 Mechanical Connection

When assembling the AwIDESULF, all components provided by Awite must be used as intended (Chapter 8). A flexible pipe must be laid from the valves to the addition points at the respective fermenters.

- Material: flexible or solid plastic pipe 1"
- Pipe lengths of 100m and more are possible at the specified cross-sections (please inform Awite in advance about the pipe lengths and the expected biogas volume flows so the right compressor can be chosen)
- A connection with G1" external thread is to be set up on-site at the point of supply
- At this connection a check valve (spring closed) is mounted (supplied by Awite). The mounting direction must be taken into account.
- It is recommended to install a distribution device for the fed-in air or oxygen inside the fermenter.

DANGER

In order to prevent a backflow of the gas into the air supply line and its environment, valves and/or check valves are provided depending on the model. You must by all means connect these components as intended.

8.5 Electrical Connection

DANGER

Dangerous electrical voltage is present at the terminals in the terminal box and the cables fed. An incorrect connection may lead to electrical hazards and even death. For information on the allocation of the different terminals and the wiring in the terminal box, please refer to the electric diagram provided as part of the system. Check the connections afterwards.

WARNING

Incorrectly dimensioned cables can lead to fire and electrical hazards. Use only cables as specified.

The connection of AwiDESULF is implemented according to the provided electric diagram. The solenoid valves for the distribution are electrically triggered and powered by the gas analysis system.

**Specification Connection Cable Valves:
AWG16 (metric equivalent 1.5mm²)
75°C / copper wire only (75°C / copper).**

The power supply for AwiDESULF 100 also takes place via the gas analysis system.

The power supply for AwiDESULF 100 UL/CSA also takes place via the gas analysis system.

The power supply for AwiDESULF 200 also takes place via the gas analysis system.

The power supply for AwiDESULF 200 UL/CSA also takes place via the gas analysis system.

For AwiDESULF 300, the power supply of the compressor takes place on-site.

The respective feed line has 3 pins (3x1.5²) 220 - 240 V

For AwiDESULF 500, the power supply of the compressor takes place on-site.

The respective feed line has 3 pins (3x1.5²) 220 - 240 V

For AwiDESULF 1000, the power supply of the compressor takes place on-site.

The respective feed line has 3 pins (3x1.5²) 220 - 240 V

**Specification Connection Cable Power Supply:
AWG16 (metric equivalent 1.5mm²)**

75°C / copper wire only (75°C / copper).

8.6 Maintenance

The intake (suction) side of the compressor is fitted with a filter. The filter pads should be checked on a regular basis and replaced when dirty. Dirty filter pads lead to a reduced air flow, whereby the motor can be damaged. Only original filter pads must be used (available at Awite).

Testing and Change interval **AwIDESULF 100:**

The filter should be checked every 3 months, it must be exchanged after 12 months.

Testing and Change interval **AwIDESULF 200:**

The filter should be checked every 3 months, it must be exchanged after 12 months.

Testing and Change interval **AwIDESULF 300:**

The intake filter has to be cleaned after 250 operating hours at the latest, and the filter cartridge must be exchanged after 3,000 operating hours. You can clean the filter by tapping it with the hand.

Testing and Change interval **AwIDESULF 500:**

The intake filter has to be cleaned after 250 operating hours at the latest, and the filter cartridge must be exchanged after 3,000 operating hours. You can clean the filter by tapping it with the hand.

Testing and Change interval **AwIDESULF 1000:**

The intake filter has to be cleaned after 250 operating hours at the latest, and the filter cartridge must be exchanged after 3,000 operating hours. You can clean the filter by tapping it with the hand.

8.6.1 Check non-return valve and solenoid valve

Since the risk is strongly influenced by on-site conditions (microbial growth, pipe distances, room ventilation and room volume, persons and installations at risk, plant size), the need for an inspection must be determined by the operator.

8.6.2 Procedure for checking the non-return valve and solenoid valve

Gas leakage from the fermenter back via the injection pipe through the air intake opening is prevented by a non-return valve and an additional solenoid valve which shuts off the path without current (closed-circuit current principle). In case of defect/contamination/fouling of the non-return valve and simultaneous defect/contamination of the electric valve or undetected failure of the compressor, gas may flow back. The probability of ignition of the atmosphere inside the compressor is considered to be low. Depending on the pressure in the fermenter, the length of the pipe and the ventilation conditions

in the room, a hazardous atmosphere may form outside the suction point. **We therefore recommend installation in a sufficiently ventilated room.**

If a hazardous atmosphere may arise in the suction chamber due to the pressure conditions, pipe length, pipe diameter, and ventilation conditions, we recommend that the function of the non-return valve and/or the solenoid valve be checked regularly.

Possible diagnostic options include:

- Shut down the compressor and check for gas leakage at the air intake opening.
- Removal of the non-return valve and visual inspection
- Evaluation of the opening and closing sound of the non-return valve and the solenoid valve.
- Assessment of noise and presence of intake vacuum
- Disassembly of the hose and checking the methane concentration on the air side of the non-return valve.
- Checking the oxygen concentration in the fermenter: if the set point of the controller is permanently exceeded (due to a valve malfunction) or not reached at all (due to failure of the compressor).

An active application of negative pressure is not recommended, because this can temporarily suck back the ball of the non-return valve in the event of another malfunction and a permanent functioning is simulated.

Awite's suggested method for checking the non-return valve is:

1. Shut down compressor
2. Immediately afterwards check for gas flow or measure methane concentration
3. Continue checking/measuring for 100 seconds (1 switching cycle)
4. Restart compressor

At 2. to 3. no gas flow (detection limit 0.1 liter per second) and/or no methane may be detected (detection limit 1000 ppm). The gas flow can also be checked qualitatively (moisten fingers or use foam).

The non-return valve must be removed and cleaned/replaced if necessary.

A detailed risk assessment can be obtained from Awite upon request.

9 AwiLAB Gas analysis

The product family AwiLAB was developed especially for laboratory applications in the biogas sector. In combination with the AwiFLEX gas analysis system, gas production and gas composition can be automatically controlled and checked during the substrate fermentation. The Fig. 26 shows the exemplary system setup including the gas analysis device AwiFLEX. The gas samples reach the AwiLAB extension via the maximum of 7 process connections. The gas quantities can be recorded with a maximum of 3 milligas counters or drum gas meters per measuring point. AwiLAB organizes the automatic release for the measurement and the automatic emptying of the bags after the measurement. The current status can be displayed via a maximum of 7 LED indicator lights.

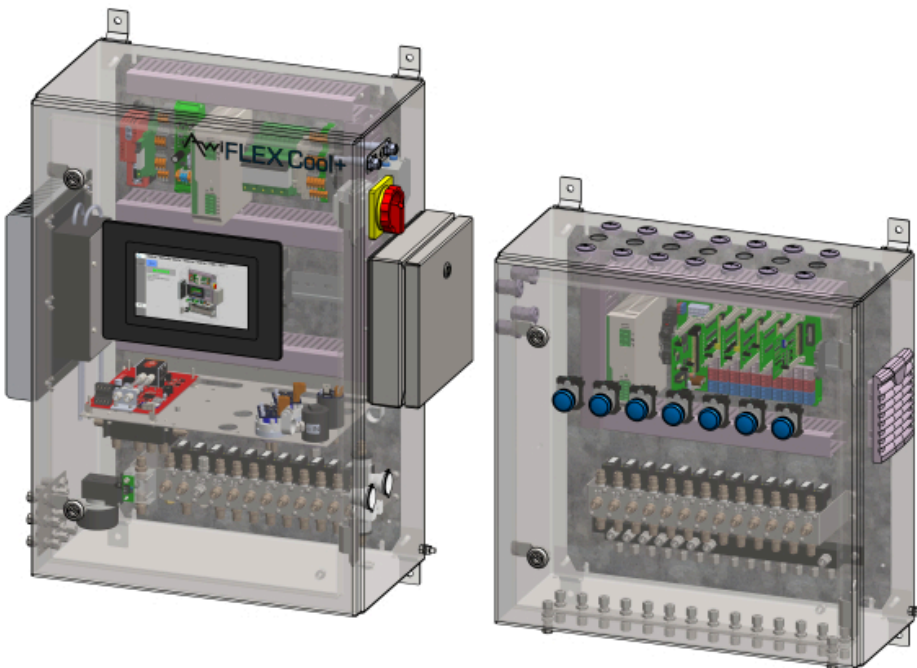

Figure 26: Schematic Illustration of AwiLAB Including Gas Analysis System AwiFLEX

9.1 Required Space

For information on the required space for the AwiLAB extension, please refer to the following illustrations.

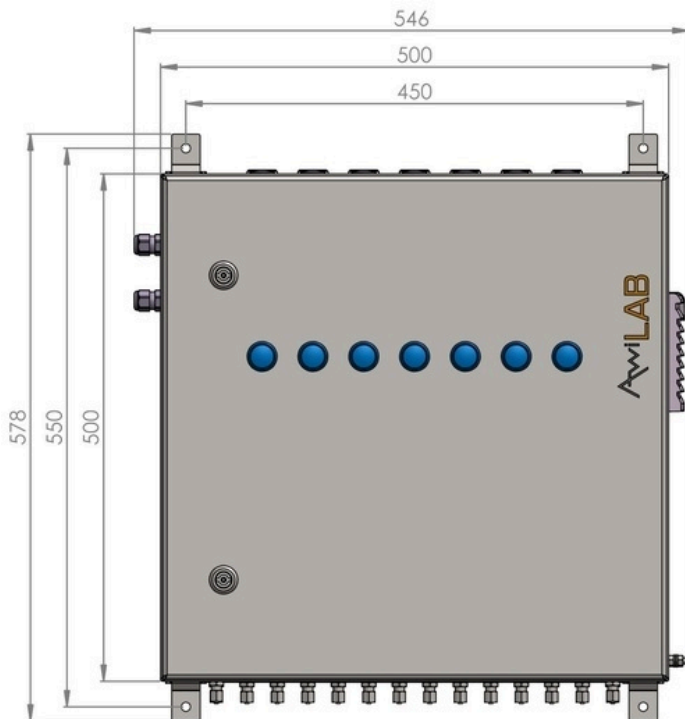

Figure 27: Required space for AwiLAB

9.2 Mechanical Connection

The reactors are 4/6mm connected to the milligas counters or the drum gas meters (4/6mmstainless steel hose connections). From there, the 4/6mm hose lines lead into the AwiLAB via a condensate trap AwiKon. Depending on the process, the discharge of the samples occurs either into a gas bag or via a technically permanently leak-tight pipe, from the installation room normally into the open environment (for more information on this, see Chapter 5.2.6.5, "Exhaust air - Discharge of the Measuring Gas"). A 4/6mm line leads directly to the gas analysis system to measure the samples.

9.3 Electrical Connection

The milligas counters or the drum gas meters, respectively, are connected to the AwiLAB using a 3.5mm jack plug (3-pin). The voltage supply for the AwiLAB takes place directly via the AwiFLEX gas analysis system via a 3-pin (3 x 1.5²) feed line (230 V). The AwiLAB is controlled via RS485 bus. The assignment can be found in the included electrical plan.



DANGER

Disconnecting the connection cable between the AwiLAB and the milligas counter or the drum gas meter, respectively, during operation may lead to faulty controls. This can cause excessive pressure in the connected collecting gas bags, which could then lead to damage and thus to gas leakage. Before conversion work, the gas analysis system must be de-energized.

10 AwiVac

The AwiVac serves as a support for the gas analysis, especially in the negative pressure range down to minus 350mbar, or for the suction of the sample gas from measuring points that are more than 100 meters away from the installation site of the gas analysis system. It is thus possible to easily analyse the gas composition in the specified negative pressure or from more distant measuring points. A special filter prevents water from entering and thus protects the other components. The built-in precision pressure regulator protects the gas analysis from excessive pressure. Using two redundant overflow valves, the gas not required for the measurement is fed into the exhaust air via a separate outlet.

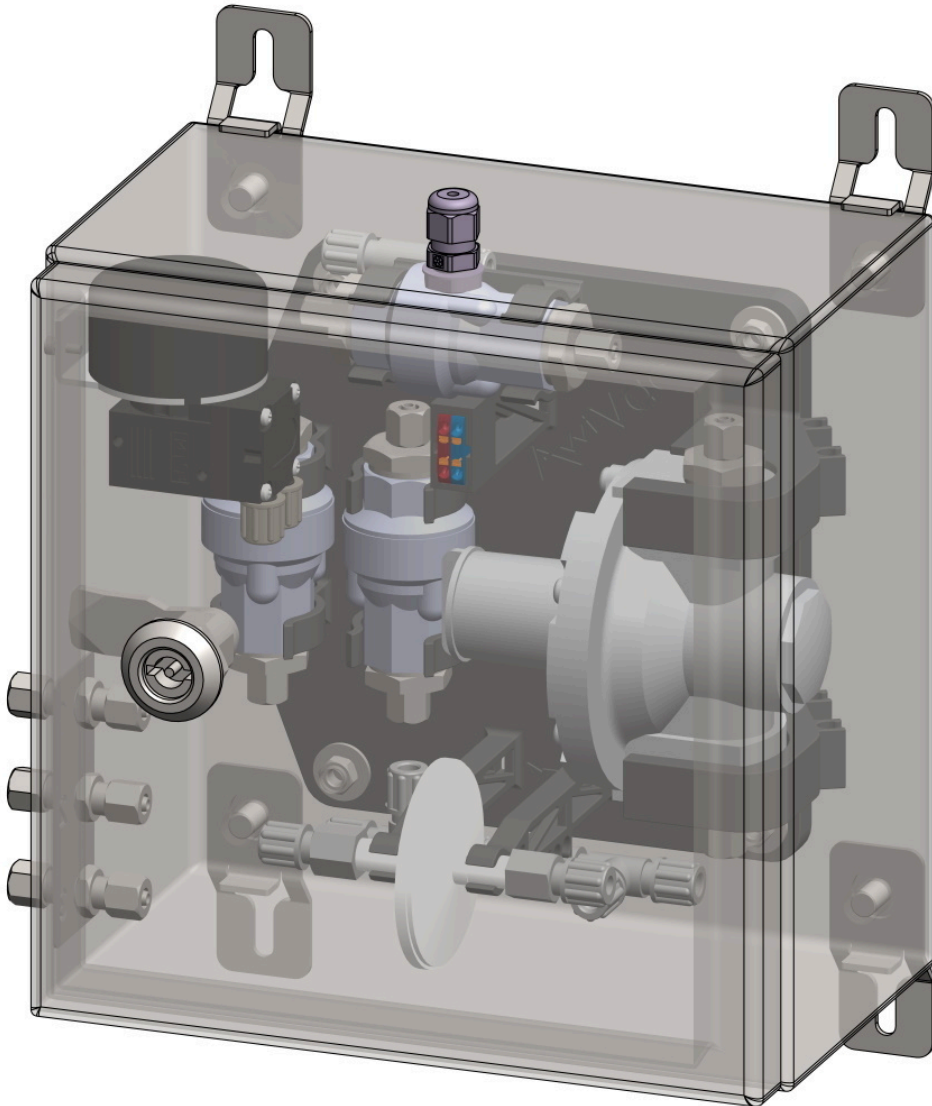

Figure 28: Schematic representation of AwiVac

10.1 Required Space

The AwiVac consists of a stainless steel housing that is connected directly to the gas analysis system. For information on the required space for the AwiVac extension, please refer to the following illustrations.

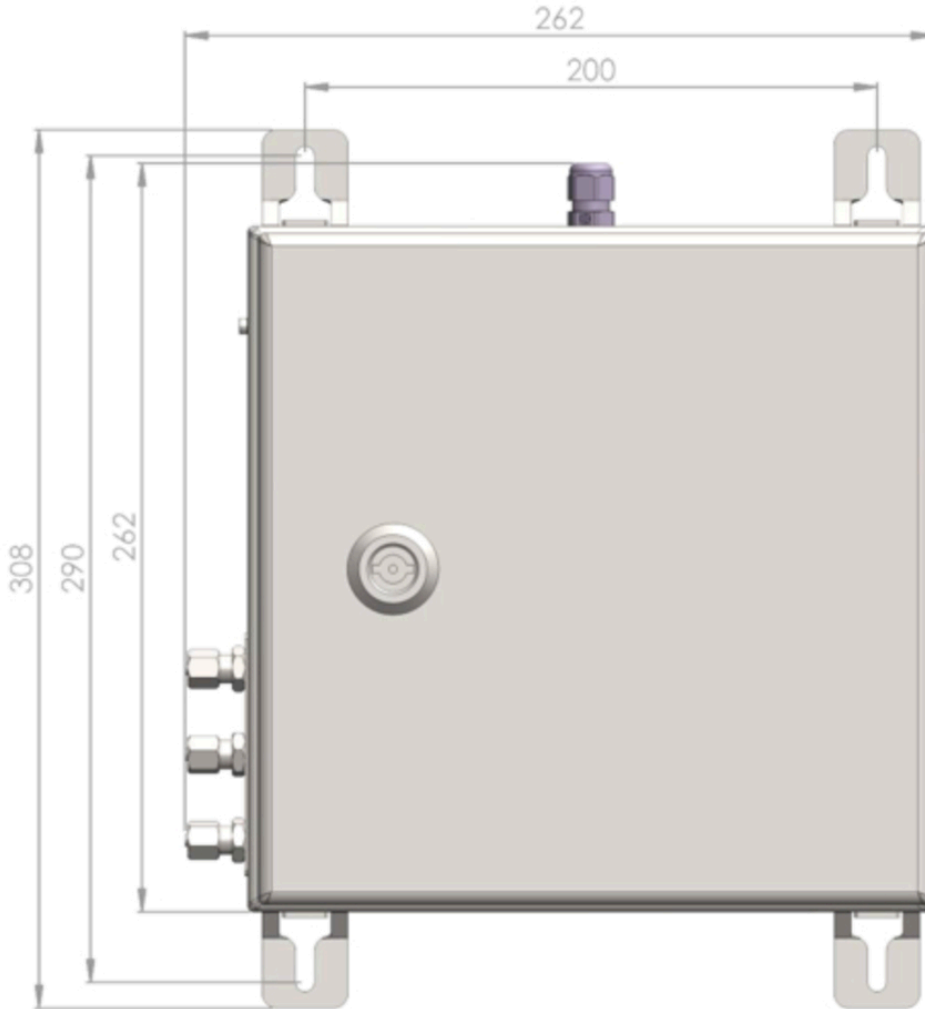

Figure 29: Required space for AwiVac

NOTE

The installation position must be observed as in image (Fig. 29).

10.2 Assemblies in the Awivac

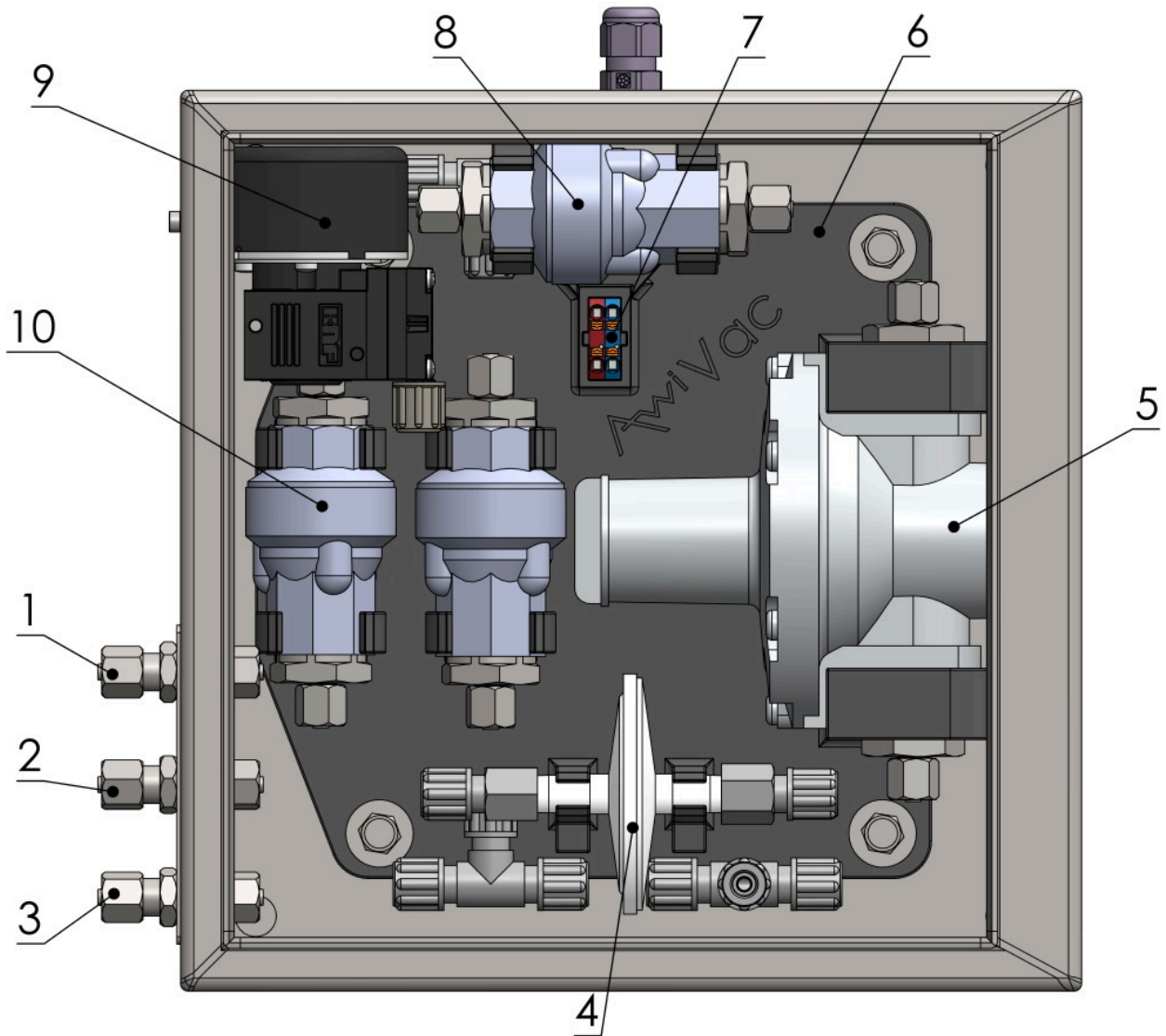

Figure 30: Assemblies in the Awivac

1: Connection analysis gas inlet	6: Mounting plate
2: Connection analysis gas outlet	7: Cable clamps
3: Connection exhaust air	8: Non return valve RM20
4: Water trap	9: Micro membrane pump
5: Precision pressure regulator	10: Excess flow valve RZ21 / RZ22

10.3 Mechanical Connection

Ensure that the sample gas lines used are sufficiently pressure-resistant. There are three mechanical hose connections for 4/6mm on the outer side of the housing of the AwiVac (optionally, other connection versions are also possible).

- Connection 1: Analysis gas inlet from gas analysis system
- Connection 2: Analysis gas outlet to gas analysis system
- Connection 3: Exhaust air

The exhaust air is usually conducted outside, and this outlet must be designed exactly like in the case of the exhaust air from the gas analysis system. You can find more information specifically on exhaust air in chapter (Chapter 5.2.6.5)

DANGER

gas may escape from the exhaust gas pipe of the AwiVac during normal operation. This gas may be combustible and toxic. This may lead to fire, explosion and poisoning. Do not release the exhaust gas inside the building.

WARNING

The exhaust pipe of the AwiVac is required for a safe pressure limitation. The gas must be able to drain off. When discharging into closed gas rooms and lines, make sure that 1 l / min does not build up a pressure of more than 200 mbar in order not to exceed the permissible pressure of 400 mbar on the integrated precision pressure regulator.

WARNING

Sample gas can escape at the exhaust connection of the AwiVac. When introducing sample gas into gas-carrying lines, the possibility of creating an explosive atmosphere must be taken into account. Either feed into an Ex zone 1 or into an area in which the gas flows continuously.

NOTE

The exhaust pipe of the AwiVac is necessary for the pressure limitation. An introduction into areas with negative pressure interferes with the proper gas flow to the measuring device. The exhaust air must not be combined with the exhaust air from the gas analysis system.

10.4 Electrical Connection

The power supply and control of the AwiVac takes place directly via the gas analysis system. The assignment can be found in the included electrical plan.

11 AwiWarn

Awite uses the sensor **Honeywell GWS Sensepoint XCD** as gas warning sensor AwiWarn. For all information and instructions directly relating to the sensor, you may contact the manufacturer - Honeywell - directly:

www.honeywellanalytics.com

AwiWarn is used to monitor the housing interior of the gas analysis system. The residual risk of gas leakage inside the device can be reduced and the penetration of a dangerous atmosphere into the device from outside can be detected.

If a hazardous atmosphere is detected, the power supply and all signal lines to the gas analysis system must be switched off for safety reasons in order to disconnect potential ignition sources. Certain Awite gas analysis systems with AwiWarn may therefore be located in an EX zone 2. Further information is available from Awite on request.



Figure 31: AwiWarn - Honeywell GWS Sensepoint XCD

11.1 Installation AwiWarn

When the gas analysis system is delivered, the AwiWarn is not yet installed in the housing and is included in the delivery as an accessory in a separate box. The AwiWarn is screwed into the upper side of the housing. The installation must be carried out as follows:

1. Unscrew the plastic protective cap on the upper side of the housing
2. Take the AwiWarn out of the cardboard box and screw the white protective sleeve off the measuring head
3. Protective cap and protective sleeve serve as transport protection, are no longer needed and can be disposed of
4. Screw the AwiWarn into the housing from above until the sensor is firmly seated and the display faces forward

NOTE

The packaging box of the AwiWarn also contains a magnetic pen, which is needed to operate the transmitter on the sensor.

11.2 Required Space

The transmitter of the AwiWarn is positioned on the upper outside of the stainless steel housing, the measuring head directly below it inside the housing. For information on the additionally required space for the AwiWarn extension, please refer to the following illustrations.

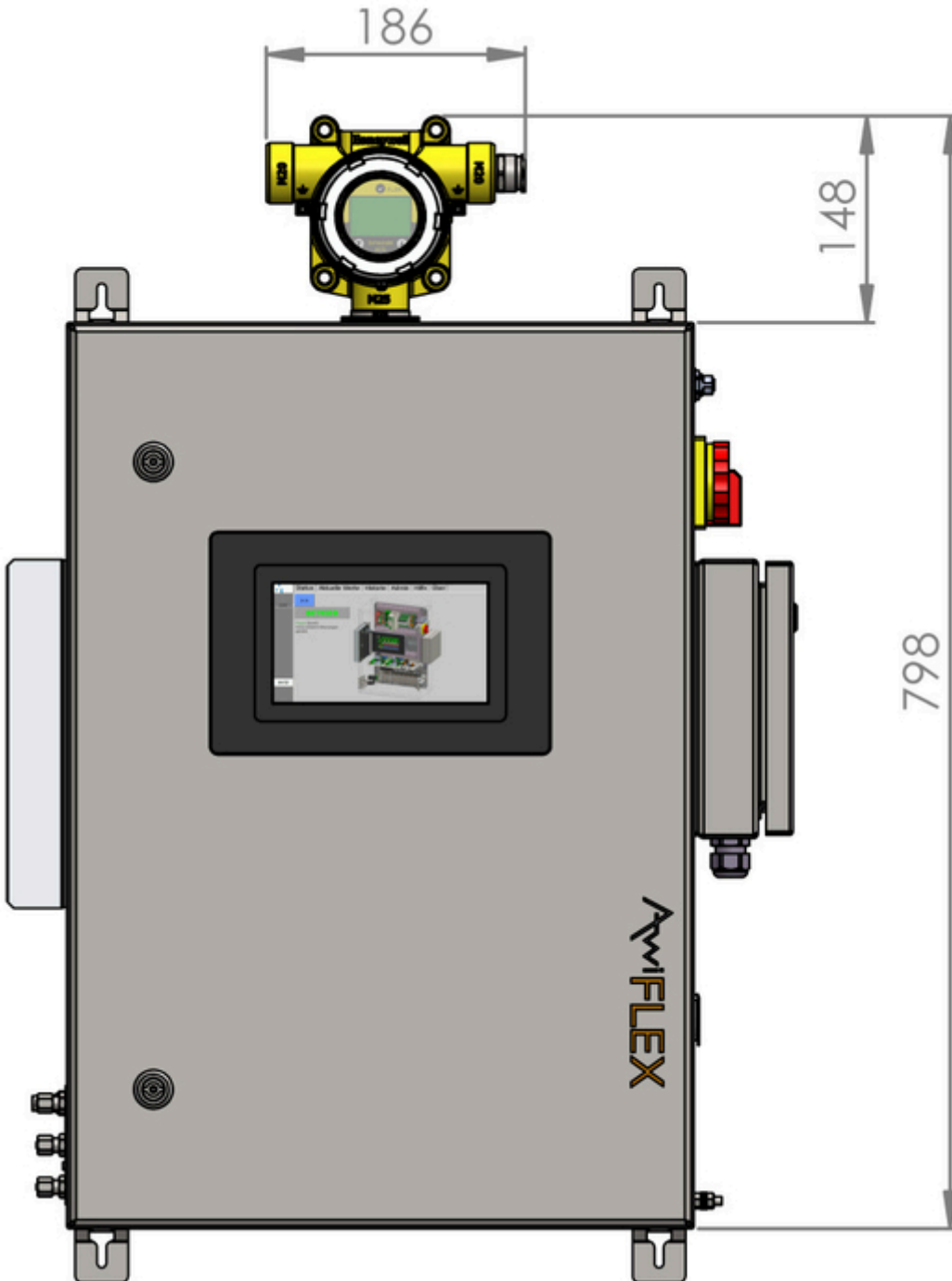

Figure 32: Required Space AwiWarn

11.3 Electrical Connection

The supply voltage must be supplied from external sources and must always be available. Even in the event of a gas alarm, it must not be switched off. In case of a gas warning, the power supply and all signal lines to the gas analysis system must be switched off on-site. Once the value is back below pre-alarm, power to the gas analysis system can be restored.

The 24VDC power supply must be designed with power limitation (back-up fuse for 4A slow blow or 5A fast blow). Otherwise the approval of the gas analysis system expires.

The transmitter is equipped with screw terminals to accommodate conductors with a cross-section of 0.5 mm² to 2.5 mm² (20 AWG to 13 AWG) and relay 3x5A for 250 VAC. The assignment can be found in the included electrical plan.

11.4 Settings and calibration

The AwiWarn CH4 has three preset alarms:

- A1 pre-alarm gas warning system (10% LEL) / contact closed if OK
- A2 main alarm gas warning system (20% LEL) / contact closed if OK
- Combined fault gas warning system / contact closed if OK

For information on changing these settings, please also contact the manufacturer Honeywell (www.honeywellanalytics.com)

In order to permanently meet the safety requirements regarding the detection of the intrusion of a dangerous atmosphere from outside (zone 2) into the device, the AwiWarn needs to be calibrated at least once a year. More detailed information on this can be requested from Awite. The calibration of the AwiWarn can be carried out directly by Awite.

12 Annex

12.1 Declarations of Conformity

The gas analysis system can optionally be designed to be installed in the potentially explosive zone 2. Which declaration applies to the respective device can be determined using the marking on the left side of the device.

12.1.1 CE Declaration of Conformity for Devices Not Intended to be Installed in an Ex-Zone

EG-Konformitätserklärung (original) EC Conformity Declaration (translation)



Hersteller, Manufacturer:

**Awite Bioenergie GmbH
Grünseiboldsdorfer Weg 5
D-85416 Langenbach**

Produkt, Product:

Prozessanalyse-System, Process analysis system

Typenbezeichnung, Type designation:

Serie 10, Series 10 (AwiFLEX, AwiFLEX XL und AwiECO)

Das bezeichnete Gerät inklusive Zubehör entspricht den aufgeführten EU-Richtlinien und Normen.

The denoted device including accessories corresponds to the listed EU guidelines and standards.

Richtlinien, Guidelines:

2006/42/EG

Es entspricht außerdem folgenden EU-Richtlinien bzw. hält deren Schutzziele ein:

2014/34/EU, 2014/30/EU, 2014/35/

It also corresponds to the listed EU guidelines or complies with their protection targets:

EU, 2011/65/EU

Normen (auszugsweise), Standards (in part):

**EN 61010-1, EN 61326-1,
EN ISO 12100-1, EN ISO 80079-36,
EN 60204**

Kennzeichnung, Marking:

CE  **II 2/- G IIA**

Gasführende Leitungen mit brennbarem oder explosivem Gas (Zone 2 oder 1 im Inneren der Leitung) dürfen an das Gerät an der vorgesehenen Stelle angeschlossen werden. Das Gerät selbst ist außerhalb einer gefährlichen Atmosphäre zu montieren.

Gas pipes with combustible or explosive gas (zone 2 or 1 inside the pipe) may be attached to the device at the designated and appropriate place. The device itself is to be installed outside of a hazardous atmosphere.

Langenbach, 21. Januar 2019, 21st January 2019

Dr.-Ing. Ernst Murnleitner

(Geschäftsleitung und Ansprechpartner bei Rückfragen, Management and contact person for queries)

12.1.2 CE Declaration of Conformity for Devices Intended to be Installed in an Ex-Zone

EG-Konformitätserklärung (original) EC Conformity Declaration (translation)



Hersteller, Manufacturer:

**Awite Bioenergie GmbH
Grünseiboldsdorfer Weg 5
D-85416 Langenbach**

Produkt, Product:

Prozessanalyse-System, Process analysis system

Typenbezeichnung, Type designation:

Serie 10, Series 10 (AwiFLEX, AwiFLEX XL and AwiECO)

Das bezeichnete Gerät inklusive Zubehör entspricht den aufgeführten EU-Richtlinien und Normen.

The denoted device including accessories corresponds to the listed EU guidelines and standards.

Richtlinien, Guidelines:

**2014/34/EU, 2014/30/EU, 2014/35/EU,
2011/65/EU**

Normen (auszugsweise), Standards (in part):

**EN 61010-1, EN 61326-1, EN ISO 12100-1,
EN ISO 80079-36, EN 60204, EN 60079-15**

Kennzeichnung, Marking:

CE Ex II 2/3 G Ex nC ec IIA/IIC T1 Gc X

Gasführende Leitungen mit brennbarem oder explosivem Gas (Zone 2 oder 1 im Inneren der Leitung) dürfen an das Gerät an der vorgesehenen Stelle angeschlossen werden. Für Gase der Gruppe IIB und IIC ist die entsprechende Detonationsschutzsicherung zu verwenden. Das Gerät selbst darf in Zone 2 Gas IIC installiert werden: Elektrische Steckverbindungen dürfen nur im spannungsfreien Zustand gezogen werden. Der Innenraum des Gerätes muss mit einem geeigneten Warnsensor überwacht werden und die entsprechenden Stromkreise gegebenenfalls spannungslos geschaltet werden. Die Zündschutzarten nC und ec beziehen sich auf die Aussenseite der Anzeige bzw. auf den integrierten den Anschlusskasten.

Gas pipes with combustible or explosive gas (zone 2 or 1 inside the pipe) may be attached to the device at the designated and appropriate place. The suitable detonation arrester must be used with gas IIB or IIC. The device itself may be installed in zone 2 gas IIC: Electrical connections must not be separated under voltage. The volume inside the device must be detected by means of a suitable warning sensor and the power circuits have to be disconnected from mains if necessary. The types of protection nC and ec refer to the outside of the display and the integrated terminal box respectively.

Langenbach, 2. Juli 2021, 2nd July 2021

Dr.-Ing. Ernst Murnleitner

(Geschäftsleitung und Ansprechpartner bei Rückfragen, Management and contact person for queries)

12.1.3 UKCA Declaration of Conformity for Devices Not Intended to be Installed in an Ex-Zone

UKCA-Conformity Declaration



Manufacturer: **Awite Bioenergie GmbH
Grünseiboldsdorfer Weg 5
D-85416 Langenbach**

Product: **Process analysis system**

Type designation: **Series 10
(AwiFLEX, AwiFLEX XL und AwiECO)**

The denoted device including accessories corresponds to the listed UK legislation and standards.

UK legislation: - Supply of Machinery (Safety) Regulations 2008

It also corresponds to the listed UK guidelines or complies with their protection targets: - Equipment and Protective Systems Intended for use in Potentially Explosive Atmospheres Regulations 2016
- Electromagnetic Compatibility Regulations 2016
- Electrical Equipment (Safety) Regulations 2016
- The Restriction of the Use of Certain Hazardous Substances in Electrical and Electronic Equipment Regulations 2012

Standards (in part): - BS 61010-1 / BS 61326-1 / BS ISO 12100-1 /
BS ISO 80079-36 / BS 60204

Marking: **UK
CA**  **II 2/- G IIA**

Gas pipes with combustible or explosive gas (zone 2 or 1 inside the pipe) may be attached to the device at the designated and appropriate place. The device itself is to be installed outside of a hazardous atmosphere.

Langenbach, 16th February 2021

Dr.-Ing. Ernst Murnleitner
(Management and contact person for queries)

12.1.4 UKCA Declaration of Conformity for Devices Intended to be Installed in an Ex-Zone

UKCA-Conformity Declaration



Manufacturer: **Awite Bioenergie GmbH**
Grünseiboldsdorfer Weg 5
D-85416 Langenbach

Product: **Process analysis system**

Type designation: **Serie 10**
(AwiFLEX, AwiFLEX XL, AwiECO)

The denoted device including accessories corresponds to the listed UK legislation and standards.

UK legislation	<ul style="list-style-type: none"> - Equipment and Protective Systems Intended for use in Potentially Explosive Atmospheres Regulations 2016 - Electromagnetic Compatibility Regulations 2016 - Electrical Equipment (Safety) Regulations 2016 - The Restriction of the Use of Certain Hazardous Substances in Electrical and Electronic Equipment Regulations 2012
Standards (in part):	<ul style="list-style-type: none"> - BS 61010-1 / BS 61326-1 / BS ISO 12100-1 / BS ISO 80079-36 / BS 60204 / BS 60079-15

Marking: **UK CA**  **II 2/3 G Ex nC ec IIA/IIC T1 Gc X**

Gas pipes with combustible or explosive gas (zone 2 or 1 inside the pipe) may be attached to the device at the designated and appropriate place. The suitable detonation arrester must be used with gas IIB or IIC. The device itself may be installed in zone 2 gas IIC: Electrical connections must not be separated under voltage. The volume inside the device must be detected by means of a suitable warning sensor and the power circuits have to be disconnected from mains if necessary. The types of protection nC and ec refer to the outside of the display and the integrated terminal box respectively.

Langenbach, 2nd July 2021

Dr.-Ing. Ernst Murnleitner
 (Management and contact person for queries)

12.1.5 IEC - Conformity Declaration

International Conformity Declaration

IEC



Manufacturer:	Awite Bioenergie GmbH Grünseiboldsdorfer Weg 5 D-85416 Langenbach
Product:	Process analysis system
Type designation:	Series 10 (AwiFLEX, AwiFLEX XL und AwiECO)
Standards (in part):	IEC 61010-1, IEC 61326-1, ISO 12100-1, IEC 60204, IEC 60079-10-1

Safety Statement / Annotations Regarding the Device Safety

Proven in Use

Awite has installed more than 3000 Process analysis devices worldwide. Construction, materials, risk assessment, monitoring and quality management ensures that the devices are safe.

CSA/UL 61010 Certification

The Awite AwiEco/AwiFlex devices are constructed and tested in order to fulfill all requirements of CSA-C22.2 no 61010-1:2012-05 and UL 61010-1:2012-05 (and also IEC 61010 and EN 61010). Intended use is the measurement of methane and biogas and the documentation is part of the certification. Conformity according to CSA 61010 and UL 61010 is continuously checked by TÜV SÜD which is a recognised NRTL in Canada and USA. Release of hazardous gas is amongst the hazards which are covered by the standard (electric shock or burn, mechanical hazards, spread of fire from the equipment, excessive temperature, effects of fluids and fluid pressure, effects of radiation, liberated gases, explosion and implosion). The conformity regarding liberated gases is checked by review of the documentation of the manufacturer. The standard does not cover non safety related topics, EMC (IEC 61326) and protective measures for explosive atmospheres (IEC 60079 series). That means that the device is safe in normal operating areas but the UL/CSA marking does not allow to install it in explosive atmospheres. Note: The European ATEX marking "Ex II 2/- G IIA" means only that the device may be attached to Zone 1 gas but not installed in such an area.

TÜV SÜD AMERICA INC. (with TÜV SÜD Product Service GmbH) is an accredited body for product safety in both, United States and Canada. More information about the certification and the test report can be obtained on request.

No Zone According IEC 60079-10-1

The device contains tubes and sensors which are not absolutely gas tight. Small amounts of gas may diffuse through them. Through the tubes and through sensors during measurement however less gas diffuses into the housing of the device than is released to the outside. Therefore the ventilation is regarded to be sufficient and no hazardous zone is generated inside the device. The leak rate of the device is so small, that also outside of the device no zone is generated by the device.

The transfer rate of gas from the inside of device interior into the room where the device is installed is at least $k = 0,07 \text{ h}^{-1}$ according to equation:

$$k = \frac{C_{max} - C_{min}}{\frac{2}{3} * C_{max} + \frac{1}{3} * C_{min}} * \frac{2}{t}$$

A pressure test (40 mbar, twice of nominal pressure according IEC 61010) is made with each device before delivery, whereby a maximum permissible pressure loss of 5 mbar is allowed in 6 minutes (2 mL Gas; safety factor 20). The electrochemical sensors which are only periodically exposed to a permissible pressure loss of 8 mbar/min may not be exceeded (safety factor 3).

Arcing, Sparking and Hot Surfaces

Normally, there is no risk of arcing, sparking or hot surfaces on the outside of the device. There is also no risk of arcing, sparking or hot surfaces inside, if no cables are disconnected during operation, the device is kept closed and there no condensing moisture and not much dust inside. This is normally fulfilled because the interior is slightly heated and thus no condensing occurs inside and there is no fan built in. The device is however not tested according to IEC 60079 series standard and the behaviour strongly depends on the type and extent of pollution.

The hot infrared source cannot ignite hazardous atmosphere (tested by DEKRA Germany).

Risk Assessment

A risk assessment according to the Machinery directive according to ISO 12100-1 „Safety of Machinery“ is re-assessed for all product modifications.

EMC

IEC 61326-1 “Electrical equipment for measurement, control and laboratory use. EMC requirements. General requirements“ is applied for electromagnetic compatibility.

Connection Sampling to Hazardous Gas

Tubes inside the device have an inner diameter of 4 mm. Tests with 11 cm long tubes (Propane) and literature review showed that the tubing works as a flame arrester. Therefore no extra flame arresters are needed if gas like methane or propane (IEC: Gases IIA) are connected. If high hydrogen concentrations are in the gas, flame arresters are needed.

Remark:

 II 2/- G IIA

The **2/-** in the marking means that gas from zone 1 is sucked in, the device itself however is placed outside of the zone.

Connection Air Supply to Hazardous Gas

The standard ISO 80079-36 „Non-electrical equipment for explosive atmospheres - Basic method and requirements“ is used in the risk assessment for the option „AwiDesulf“, where non electrical components are built in into a potential hazardous atmosphere.

Langenbach, 27th November 2020



Dr.-Ing. Ernst Murnleitner

(Management and contact person for queries)

12.2 Certificat TÜV SÜD UL - CSA 61010-1-2012

ZERTIFIKAT • CERTIFICATE • 認證證書 • СЕРТИФИКАТ • CERTIFICADO • CERTIFICAT



CERTIFICATE

No. U8 17 12 83160 002

Holder of Certificate: Awite Bioenergie GmbH

Grünseiboldsdorfer Weg 5
85416 Langenbach
GERMANY

Production Facility(ies):

83160

Certification Mark:



Product:

**Control units
(process analysis system)**

Model(s):

AwieCO, AwifLEX Cool+ and AwifLEX Cool+XL

Parameters:

Rated voltage: 100-240 V
Rated frequency: 50/60Hz
Protection class: I
Rated power: 30 W (AwieCO)

Rated power:
up to 600 W (AwifLEX Cool+, depends on number of external de-sulphurisation units)

Rated power:
up to 680 W (AwifLEX Cool+XL, depends on number of external desulphurisation units)

Tested according to:

UL 61010-1:2012-05
CAN/CSA-C22.2 no. 61010-1:2012-05

The product was voluntarily tested according to the relevant safety requirements noted above. It can be marked with the certification mark above. The mark must not be altered in any way. This product certification system operated by TÜV SÜD America Inc. most closely resembles system 3 as defined in ISO/IEC 17067. Certification is based on the TÜV SÜD "Testing and Certification Regulations". TÜV SÜD America Inc. is an OSHA recognized NRTL and a Standards Council of Canada accredited certification body.

Test report no.: 028-713122858-000

Date, 2017-12-20
Page 1 of 1



TÜV SÜD AMERICA INC. • 10 Centennial Drive • Peabody MA 01960 USA • www.TUVamerica.com

TUV®